

Characteristics

Electrical

Power supply

Voltage range: 216.2 - 253V
 Frequency: 50Hz (nom)
 Phases: 1
 Power: Controller 3VA (max)
 Switched output(s) 75VA
 Fuse: 1.0A slow-blow

Control Relay(s)

Contact type: SPST NO
 Switched Live -
 nominal 230VAC output
 @300mA max.

Thermocouple

Types: R type standard
 (*K, N & S type also available*)

Connectors

2-part connectors
 Max. wire size 2.5mm²

Error Handling

Thermocouple failure detection
 Thermocouple reversal detection
 Heater failure detection
 Over-temperature detection

CE This instrument complies with Council Directive 89/336/EEC (electromagnetic compatibility) & Council Directive 73/23/EEC (low voltage safety)

Temperature

Temperature Setting (t1 & t2)

Range: 0 to 1320°C
 Resolution: 1°C

Control Accuracy

P.I.D. Control
 Reading accuracy: $\pm 0.25\%$ FSD ± 1 digit

Time

Start delay range 00:00 to 19hr 59min
 Soak time range 00:00 to 19hr 59min
 Resolution: 1 min

Program

1 program with 2 ramps & 1 soak
 1st ramp rate: 10 to 399°C/hour or full power
 2nd ramp rate: 10 to 399°C/hour or full power

Environmental

Operating temperature range: 0 to +40°C
 Storage temperature range: -10° to +55°C

Enclosure

Sealing: IP65
 Material: ABS
 Colour: Light Grey RAL 7035
 Size: 120x122x58mm
 Fixings: 90x110mm (4 off)



ST302

User Handbook



ST302 Temperature Controller

Stafford Instruments Ltd. www.stafford-inst.co.uk
 Tel: +44(0)1785 604561 email: support@stafford-inst.co.uk
 Fax: +44(0)1785 602381







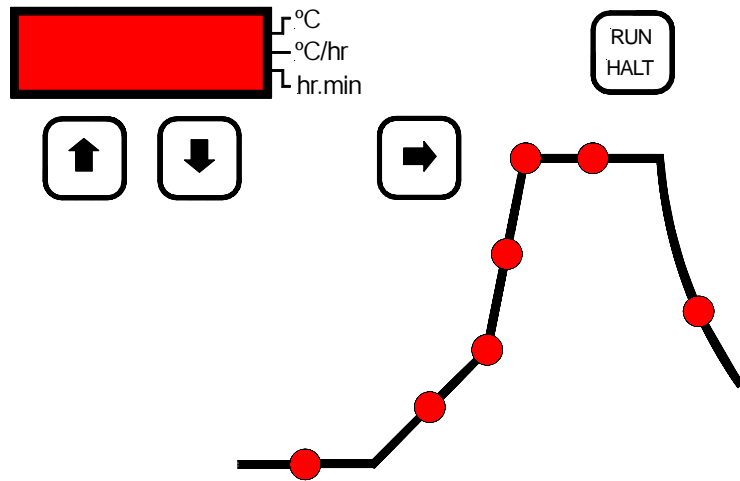

<http://www.stafford-inst.co.uk/docs/st302/user302.pdf>

Issue: 1.0A
 Date: 02 May 2000

Setting



When the controller is halted no lamps on the firing mimic curve are illuminated and the display shows the kiln temperature. The controller settings can be reviewed by pressing the \rightarrow key. Each press of the \rightarrow key selects the next settable value as evidenced by a flashing lamp on the firing curve. The currently stored value will be displayed. This can be changed, if necessary, by using the \uparrow & \downarrow keys. Holding these keys down allows rapid change in the displayed value. If no keys are pressed for 5 seconds the display will revert to showing kiln temperature. All settings are remembered when the controller is turned off.

-  Start delay: the start of a firing can be delayed in the range 00.00 to 19.59 hr.min
-  Ramp 1: this is settable in the range 10 to 399°C/hr or to FULL power. This is the initial rate of rise to temperature t1
-  t1: this can be set in the range 0 to 1320°C and is the target temperature for the initial ramp
-  Ramp 2: this is settable in the range 10 to 399°C/hr or to FULL power. This is the final rate of rise to temperature t2
-  t2: this can be set in the range 0 to 1320°C and is the final or soak temperature
-  Soak time: this can be set in the range 00.00 to 19.59 hr.min and is the time the controller dwells or soaks at temperature t2

Wiring In

If a pre-wired cable & plug is not fitted then the instrument can be wired to the kiln as shown below. The instrument is fitted with 2-part connectors to facilitate wiring. The maximum wire size is 2.5mm².

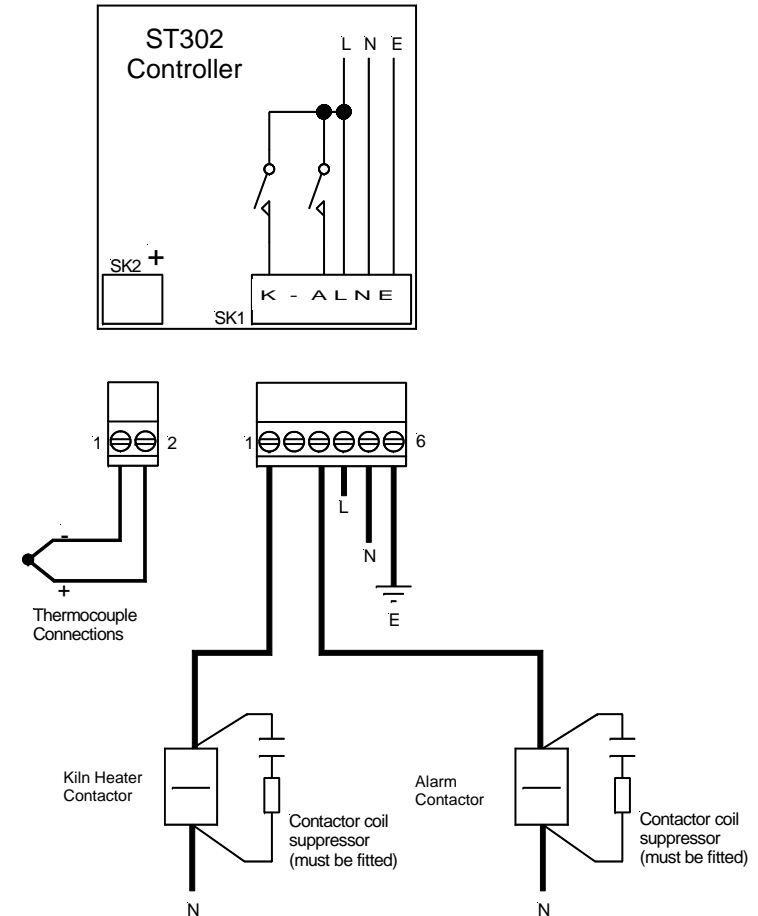

Note

The (optional) alarm relay contacts close at the start of firing and open when firing is complete. The contacts also open if the kiln temperature exceeds the required temperature by 20°C for more than 15 minutes. This relay can be used to drive a secondary contactor to isolate kiln power.

Wiring

Connector

If the instrument has been pre-wired with a cable & plug ensure that the plug is compatible with the connector fitted to the kiln. The standard connector is Harting type HAN 7D or similar.

HAN 7D Pinout

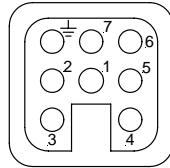

View on pins

Kiln Connections

Compatible kiln connector wiring is shown below:-

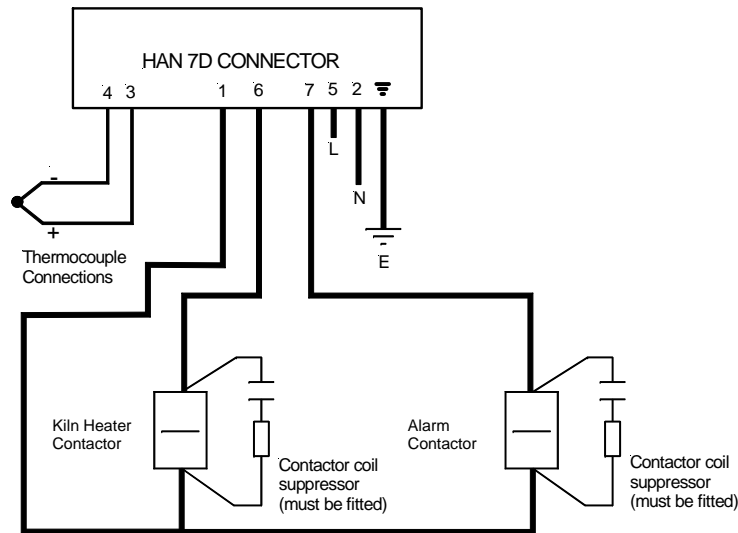

Connector Pin List

1	Neutral to contactors	5	Mains Live supply
2	Mains Neutral supply	6	Kiln Power contactor Live
3	Thermocouple +	7	Alarm contactor Live
4	Thermocouple -	Earth	Earth

Firing



Pressing this key will start a firing or abort a firing that is in progress. The status of the firing is shown on the firing mimic curve. If a start delay has been requested then the mimic start delay lamp will light and the delay time remaining will be displayed.

On commencing a firing the kiln is heated from the starting temperature to temperature **t1** at a rate determined by the **ramp 1** setting. Upon reaching **t1** the kiln will be heated at a rate determined by the **ramp 2** setting to temperature **t2**, the soak temperature. It will soak at this temperature for the **soak time**. It will then cool naturally with the lamp on the cooling section of the firing mimic curve lit. This lamp will stay on until the kiln has cooled to 40°C.

The **➡** key can be used at any time during firing to review the stored program. The **⬆** & **⬇** keys can also be used to modify program values during firing without interrupting the firing process.

During ramping the kiln temperature is displayed. During soaking the kiln temperature and the soak time remaining are displayed alternately for 5 seconds each.

An indicator in the top left of the display lights when the kiln is being heated. Another indicator near the top middle of the display lights when the keyboard is *locked* – this is an anti-tamper feature. To lock or unlock the keyboard press the **⬆** & **⬇** keys simultaneously.

Errors

Err 1

The kiln temperature is not increasing as required. Possible causes are: kiln door or lid not closed properly, heater element failure, power phase failure or thermocouple short-circuit.

Err 2

Thermocouple or thermocouple wiring open circuit. Check wiring / replace thermocouple.

Err 3

Thermocouple reversed (temperature less than -50°C). Check wiring.

Err 4

Kiln temperature has exceeded required temperature by more than 20°C for 15 minutes. The alarm relay (if fitted) has been de-energised. This indicates a kiln contactor fault. Check contactor & wiring.

Installation

Safety Warnings



ISOLATE
BEFORE
REMOVING
COVER

WARNING

ISOLATE KILN & CONTROLLER FROM ELECTRICAL
SUPPLY BEFORE OPENING THIS INSTRUMENT FOR
INSTALLATION, CONFIGURATION OR REPAIR PURPOSES

Installer Information

Installation Category: II
Pollution Class: 2

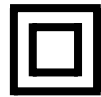

230V ~ 50HZ 1.0A

IP65

Fuse: 1.0A Anti-surge
Wickmann type TR5 T1A
250V

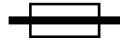

EMC

To meet Electromagnetic Compatibility requirements both the thermocouple lead and the power leads should not exceed 3.0m in length.

This instrument is designed for use mainly in Domestic & Light Industrial environments where electromagnetic interference may cause a loss of accuracy of the displayed temperature reading of up to 3°C. Specified accuracy will be restored when the interference is removed.

Contact Suppression

The coil of each contactor *must be suppressed* with an RC filter network. The RC network must be connected directly across the coil terminals on the contactor.

Suitable proprietary RC filter networks fitted with insulated wire leads are:-

- | | | |
|----|-------------------------------|------------------|
| 1. | RS Components | Part No. 210-364 |
| 2. | RS Components (tab fixing) | Part No. 210-370 |
| 3. | Farnell Electronic Components | Part No. 218-893 |

Mounting

Mounting Location

Mount the instrument on a suitable vertical surface which will not get hot. Choose a position where the instrument is not exposed to direct heat from the kiln - especially when the kiln door or lid is open.

The cable entry in the instrument base should normally be positioned downwards to guard against moisture ingress.

Mounting Centres

The mounting centres are marked on the back of the instrument enclosure and are 90mm x 110mm.

To expose the mounting holes in the instrument base remove the instrument's front panel which is secured with cross-head screws.