

# Characteristics

## Electrical

### **Power supply**

Voltage range: 216.2 - 253V  
 Frequency: 50Hz (nom)  
 Phases: 1  
 Power: Programmer: 3VA (max)  
       Switched outputs: 75VA  
 Fuse: 1.0A slow-blow

### **Control Relay(s)**

Contact type: SPST NO  
 Switched Live -  
     nominal 230VAC output  
     @300mA max.

### **Thermocouple**

R,S,K & N type.

### **Connectors**

2-part connectors -  
 Max. wire size 2.5mm<sup>2</sup>

**CE** This instrument complies with Council Directive 89/336/EEC (electromagnetic compatibility) & Council Directive 73/23/EEC (low voltage safety)

## Temperature

### **Temperature setting (t1 & t2)**

Range: 0 to 1320°C (R/S) 0 to 1200°C (K/N)  
 Resolution: 1°C

### **Control Accuracy**

P.I.D. Control  
 Reading accuracy: ±0.25% FSD ±1 digit

## Time

Start delay range: 00:00 to 99hr 59min  
 Soak time range: 00:00 to 99hr 59min  
 Resolution: 1 min

## Programs

30 program with 2 ramps & 1 soak per program  
 1st ramp rate: 1 to 399°C/hour or full power  
 2nd ramp rate: 1 to 399°C/hour or full power  
 Ramps can be heating or cooling  
 Up to 30 programs can be linked

## Environmental

Operating temperature range: 0 to +40°C  
 Storage temperature range: -10° to +55°C

## Enclosure

|                    |                           |
|--------------------|---------------------------|
| Material: ABS      | Size: 120x122x58mm        |
| Sealing: IP65      | Fixings: 90x110mm         |
| Colour: Light Grey | (4 off) + (optional) wall |
| RAL 7035           | mounting bracket          |

## Error Handling

Thermocouple failure detection  
 Thermocouple reversal detection  
 Heater failure detection  
 Over-temperature detection

## Other

Keyboard lock facility + indicator  
 Kiln heating-on indicator



# ST303

## Installation Instructions

# ST303 Temperature Programmer

Stafford Instruments Ltd.  
 Tel: +44(0)1785 604561  
 Fax: +44(0)1785 602381

www.stafford-inst.co.uk  
 email: support@stafford-inst.co.uk



# Installation

## Safety Warnings



ISOLATE  
BEFORE  
REMOVING  
COVER

### WARNING

ISOLATE KILN & PROGRAMMER FROM ELECTRICAL SUPPLY BEFORE OPENING THIS INSTRUMENT FOR INSTALLATION, CONFIGURATION OR REPAIR PURPOSES

Installation

## Installer Information

Installation Category: II  
Pollution Class: 2

230V ~ 50HZ 1.0A

Fuse: 1.0A Anti-surge  
Wickmann type TR5 T1A  
250V

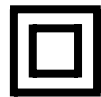

IP65

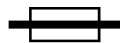

## EMC

To meet Electromagnetic Compatibility requirements both the thermocouple lead and the power leads should not exceed 3.0m in length.

This instrument is designed for use mainly in Domestic & Light Industrial environments where electromagnetic interference may cause a loss of accuracy of the displayed temperature reading of up to 3°C. Specified accuracy will be restored when the interference is removed.

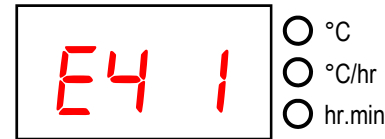

○ °C  
○ °C/hr  
○ hr.min

Error 4 message status is now displayed. This can be altered with the  $\uparrow$  &  $\downarrow$  keys. **E4 1** indicates that error 4 is enabled. **E4 0** indicates that error 4 is disabled. Press the START/STOP key.

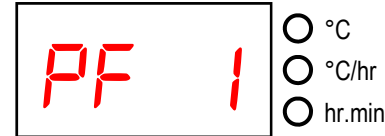

○ °C  
○ °C/hr  
○ hr.min

Power failure handling status is now displayed. This can be altered with the  $\uparrow$  &  $\downarrow$  keys. **PF 1** indicates that power failure recovery is enabled. **PF 0** indicates that power failure recovery is disabled. Press the START/STOP key.

The ST303 will now store the configuration data and then leave configuration mode by resetting itself.

*Note: error messages are provided to detect kiln faults and so offer some protection to the kiln. For increased protection the use of a heat fuse or other independent over-temperature trip (such as the Stafford Instruments ST101) is recommended.*

*For maximum protection an independent thermocouple, trip & heater contactor circuit should be used.*

*Note: error messages should normally be left enabled. Error messages should only be disabled as a short term measure—to diagnose kiln problems for example. Power fail recovery may need to be disabled if un-attended firing is not allowed.*

Installation



## Wiring

### Connector

If the ST303 has been pre-wired with a cable & plug ensure that the plug is compatible with the connector fitted to the kiln. The standard connector is Harting type HAN 7D or similar.

### HAN 7D Pinout

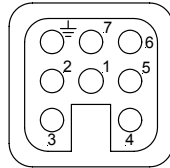

View on pins

### Kiln Connections

Compatible kiln connector wiring is shown below:-

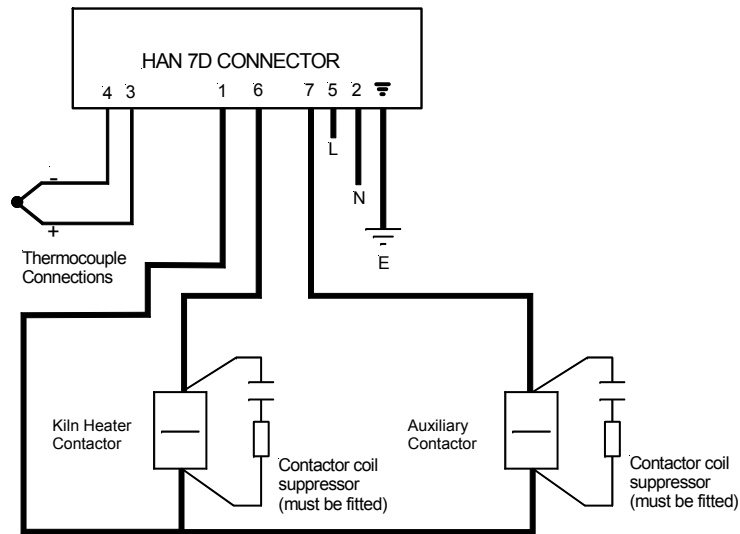

### Connector Pin List

|   |                       |       |                           |
|---|-----------------------|-------|---------------------------|
| 1 | Neutral to contactors | 5     | Mains Live supply         |
| 2 | Mains Neutral supply  | 6     | Kiln Power contactor Live |
| 3 | Thermocouple +        | 7     | Auxiliary contactor Live  |
| 4 | Thermocouple -        | Earth | Earth                     |

## Wiring In

**Wiring in should only be performed by a qualified person—preferably an experienced kiln electrician.**

If a pre-wired cable & plug is not fitted then the instrument can be wired to the kiln as shown below. The instrument is fitted with 2-part connectors to facilitate wiring. The maximum wire size is 2.5mm<sup>2</sup>.

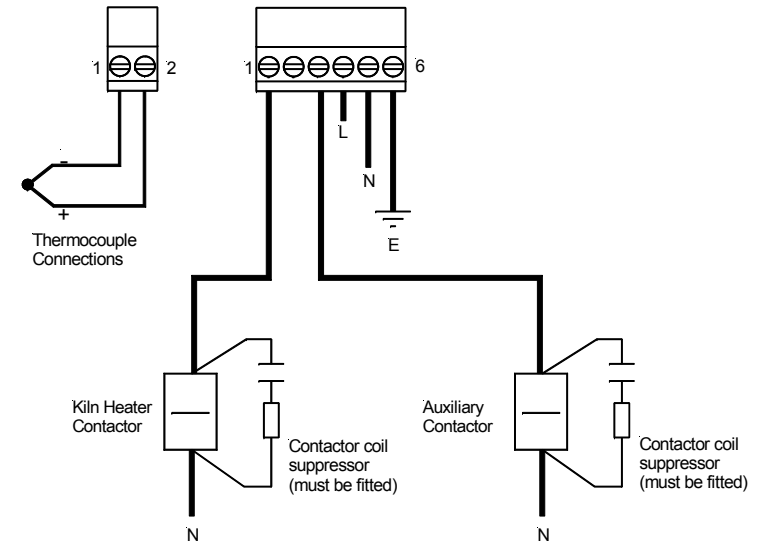
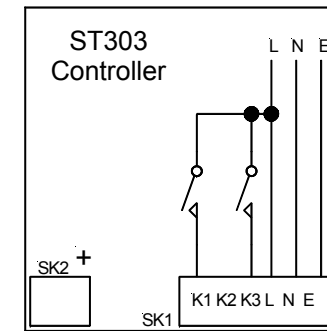

### Note

The (optional) auxiliary alarm relay contacts close at the start of firing and open when firing is complete. The contacts also open if an error message is generated. This relay can be used to drive a secondary contactor to isolate kiln power.