

A range of materials and  
equipment carefully chosen  
for the discerning  
potter, ceramicist or sculptor

Price List

where quality comes as standard

April 2012  
No. 41

**CLAYMAN**  
Supplies Limited

# Welcome

Welcome to our price list of pottery supplies. The products we offer have been selected with care and attention to detail and we are sure you will find them all to have the quality you would desire at a price that is extremely competitive.

At Clayman Supplies Limited we are passionate about ceramics and we have been for the last thirty years from our inception. We believe using the best quality aids should make the job easier or the end product better. We are also passionate about the service we give our customers. Simply, we aim to be the best.





Clayman Supplies Limited started life as Nyetimber Pottery Supplies. Reg Griggs had set up a small studio pottery, and when asked by local people if they could buy the odd bag of clay, ventured into supplying more goods. Within six months of trading it was deemed that a more appropriate name was required and Clayman Supplies Limited was chosen as the most apt for the man who sold clay. Reg now has eighteen years' experience teaching pottery and over thirty years potting in a full or part-time capacity. Over that time he has absorbed ceramic knowledge like a sponge and now spends each day offering technical support to amateurs and professionals alike. Having taught and worked as a professional potter he can offer advice that is applicable to the enquiry he is dealing with at any one time.

Linda Griggs started life as a practice manager for a group of doctors. For more than 20 years she has brought that desire for detail and efficiency to running the accounts and despatch sides of Clayman Supplies Limited. She also brings that personal touch to dealing with customers who visit our "Potters' Shop" or who telephone with orders.

Clayman Supplies Limited started in a small way, but it has not lost the belief that all customers are important. Service is a term that we grew up with and still want to practise on an every day basis.

## Important Information

Throughout this price list you may see one of the following "dashes" placed near a section heading. Read below for a description of each dash.

	All prices in this section are lower than the previous published price list
	A number of prices in this section are lower than the previous published price list
	A number of the prices in this section have been held at the previously published price list
	All the prices in this section have been held at the previous published price list.

## Our Products

### Clays

We carefully search for what we believe to be the best, even if that takes us to Australia to import white clays, because they are simply the whitest we can find anywhere.

### Brush-on Glaze & Colours

We make our own standard earthenware and stoneware glazes. We are also the official distributor of Chrysanthos Brush-on Glazes and Colours. We believe Chrysanthos offers a fantastic range of products at truly unbeatable prices.

### Wheels & Equipment

Of course the quality of our throwing wheels has to be seen to be believed. They have to do what we say they can do. We have tested them and made sure they can. You would not expect any less from a thrower would you? We have a close working relationship with the best manufacturer in the UK and then to complement this we have selected imported items.

### Kilns & Accessories

Our kilns do what we say and also the service we offer with them has to comply with what we would expect if we were buying such an important piece of equipment. The kiln must be the heart of any ceramic organisation and if that heart does not operate properly you, the customer, is going to suffer.

### Making Tools

All our tools are chosen individually to do certain tasks. They are made to a high standard to last and provide you with the assistance you would expect.

### Bisque

We are continuously increasing our range of bisque ware.

# Making Our Vision Become a Reality



## The origins of our logo...

Reg Griggs demonstrating at a craft fayre in the late 1970's - taken by a press photographer.

**Clayman** by name  
**Clayman** by nature

## Our aspiration!

We live and breath ceramics at Clayman. From carefully choosing the products we sell for quality and value for money to taking your order and making sure they are delivered to you on time and in good condition. That has always been our aim, now we have committed this vision to words in our Mission Statement.

Realising the vision of an efficient, imaginative ceramic supplier of materials and equipment has been a journey of commitment. That commitment shapes our philosophy. At Clayman:

- We will never be undersold. This applies to all branded or named products. \*Terms apply.
- We will not surcharge the use of credit cards.
- We aim to source the best products that best suit the needs of customers.
- We promote and sell only quality products from the best sources worldwide.
- Dealing with Clayman should be a pleasurable and educational experience.
- Our customer service should meet our customers' needs and expectatons.
- Our products will be only those that are affordable offering quality, consistency and value for money from reputable sources.
- We will aim to contribute constructively to the whole ceramics market.
- We will aim to be a good employer; training and developing a satisfied, skilled and motivated team.
- We will listen to customer feedback and implement changes where and when appropriate.

Note: This offer applies to all branded products, but excludes products sold under a generic name, such as Raw Materials, Oxides etc.

# Contents

Selection of small tiles - 'Amoebae', 'Hearts', 'Stars' & 'Patterns' by Angela Evans  
www.angelaevans.co.uk

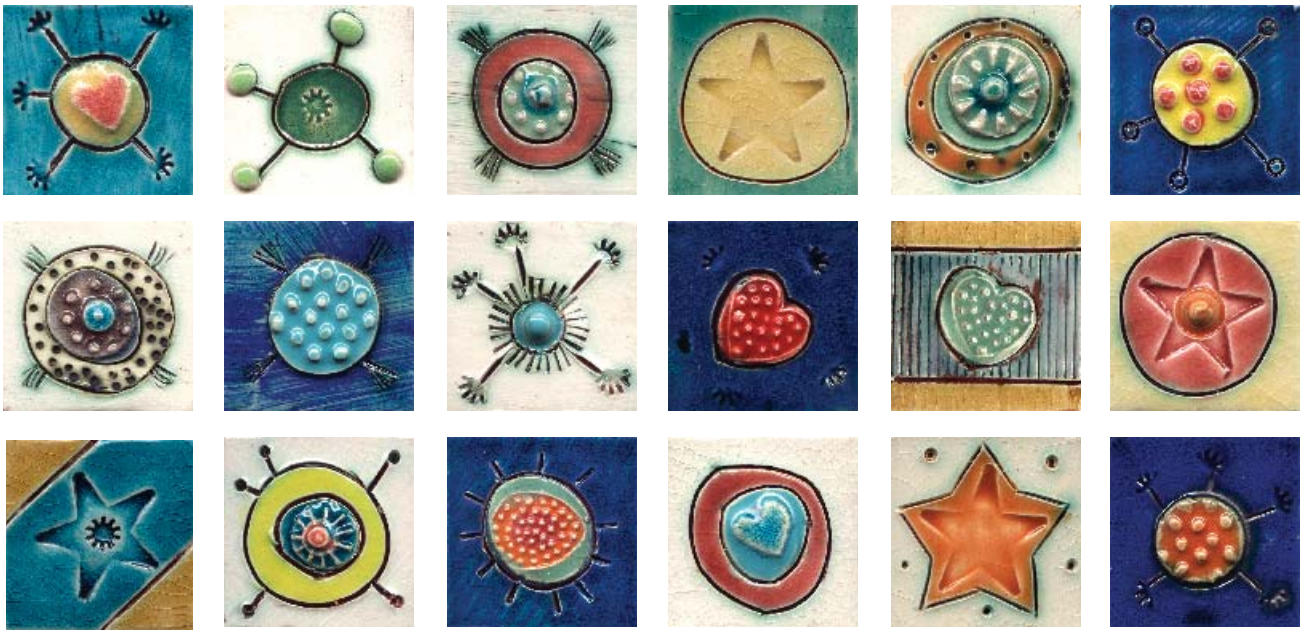

<b>Clays</b>	5-6	<b>Brushes</b>	20
Red Clays, Buff Off-White Clays, White Earthenware/ Stoneware Clays, Porcelain/ Specialist Clays, Paper Clays.		Pencils, One Strokes, Glaze Mops, Chinese, Hake, Nylon, Hogs, Lawn, Dusters.	
<b>Decorating Slips</b>	7	<b>Making Tools</b>	21-23
Liquid, Powdered.		Turning tools, Modelling Tools, Forged Steel Tools, Tool Sets, Hole Cutters, Ribs, Clay Cutters, Hand Extruders, Scraffito Tools, Needles, Slip Trailers, Bench Scrapers, Rolling equipment, Calipers Sponges, Metal Kidneys, Rubber Kidneys, Tile Cutters.	
<b>Casting Slips</b>	8	<b>Workshop Tools</b>	23
Standard, Hobby Casting Slips.		Sieves, Protective Clothing, Scales, Plastic Ware, Clay Traps.	
<b>Glazes</b>	9-12	<b>Wheels &amp; Equipment</b>	24-25
POWDERED GLAZES - Raku, Earthenware Transparent, Earthenware Opaque, Coloured Opaque Earthenware, Super Coloured Earthenware, Studio Earthenware, Mid-temperature Stoneware, Standard Stoneware Porcelain, Studio Stoneware. DIPPING GLAZES - Earthenware & Stoneware. BRUSH-ON-GLAZES - Earthenware & Stoneware.		Wheels, Accessories, Whirlers, Slab-rollers, Pugmills, Extruders, Blungers, Spray Booths, Spray Equipment, Mixers.	
<b>Colours</b>	13-15	<b>Kilns &amp; Accessories</b>	26-29
Powdered Underglazes, Stains, Brush-on, Pencils.		Front-loading, Top-loading, Controllers, Kiln Furniture etc.	
<b>Onglaze Colours</b>	16	<b>Plaster Moulds</b>	30
Onglaze powders, Precious Metal Lustres.		Press, Hump, Related tools & Materials.	
<b>Medias</b>	16	<b>Plasters</b>	31
<b>Raw Materials</b>	17	Casting, Ceramic & Dental Plasters.	
<b>Powdered Clays</b>	17	<b>Books &amp; Videos</b>	31-34
Ball Clays, China Clays, Fireclay.		General, Reference, Clay & Glazes, Beginners & Children, China Painting, Chinese Brush Painting, Plaster, Mouldmaking & Sculpture, Making Techniques, Decorating Techniques, Kilns & Firing, Slip Casting, Potter's Profile, Magazines, Miscellaneous, Videos, General Art, Hobby, Glass.	
<b>Opacifiers</b>	17	<b>Bisque Ware</b>	34-35
<b>Grogs</b>	18	<b>Useful Information</b>	36
Firebrick, Molochite, Cordierite, Chamotte.		<b>Delivery Rates</b>	37-38
<b>Frits</b>	18	<b>How to Order</b>	39
<b>Oxides</b>	18	<b>Where to Find Us</b>	40
<b>Miscellaneous</b>	19	<b>Conditions of Sale</b>	44
Materials, Liquids, Adhesives, Size.			

## Buff/ Off-White Clays in 10kg packs

Code	Buff / Off-White Clay	Maturing Range °C	Cone	Sample	10kg	20kg	50kg	100kg	250kg	500kg	1000kg
1057	OZ CRANK PLUS/RAKU	1000-1300	06-10		DISCONTINUED						

## White Earthenware/Stoneware Clays in 10kg packs

Code	White E/W - S/W Clay	Maturing Range °C	Cone	Sample	10kg	20kg	50kg	100kg	250kg	500kg	1000kg
1067	PB103 FINE WHITE S/W	1200-1300	5-10	1.50	12.29	23.32	55.15	104.00	252.00	457.00	788.00
1069	WHITE MID-FIRE S/W	1160-1260	3-8	1.50	10.82	21.12	51.50	92.40	224.50	433.00	787.00
1072	SUPER WHITE E/W	1060-1160	04-3	1.50	13.86	26.30	62.20	117.30	284.50	515.50	889.00

## Porcelain Clays in 10kg packs

Code	Porcelain Clay	Maturing Range °C	Cone	Sample	10kg	20kg	50kg	100kg	250kg	500kg	1000kg
1084	SUPERIOR PORCELAIN	1240-1300	7-10	2.00	16.11	31.68	77.20	126.80	278.25	597.50	1116.00
1086	IMPERIAL PORCELAIN	1250-1300	7-10	2.00	23.94	45.08	110.35	208.50	488.25	929.50	1784.00

## Red Clays in 12.5kg packs

Code	Red Clay	Maturing Range °C	Cone	Sample	12.5kg	25kg	50kg	100kg	250kg	500kg	1000kg
1000	SWAN BLEND	1060-1200	04-5	1.50	6.70	10.64	19.52	39.12	93.00	178.80	327.20
1020	ROCCO RED	1020-1180	05-5	1.50	5.66	9.02	16.84	33.68	80.20	156.40	280.80
1090	RED MARL TERRACOTTA	1060-1220	04-6	1.50	8.06	13.96	23.64	38.64	94.60	185.20	335.20
1095	TERRACOTTA CRANK	1080-1220	03-6	1.50	11.49	22.14	45.96	83.52	172.00	334.00	608.00

## Buff/ Off-White Clays in 12.5kg packs

Code	Buff/ Off-White Clay	Maturing Range °C	Cone	Sample	12.5kg	25kg	50kg	100kg	250kg	500kg	1000kg
1030	CLAYMAN SPECIAL BUFF	1110-1270	02-9	1.50	6.93	11.74	21.12	40.88	94.00	159.60	289.60
1035	WESSEX MIXTURE	1180-1290	5-10	1.50	9.34	15.80	28.72	51.68	115.00	201.20	379.20
1052	FEENEY'S BUFF MIX	1000-1300	06-10	1.50	16.03	30.42	57.56	108.48	263.00	476.80	822.40
1038	REALLY GOOD STONEWARE	1180-1290	5-10	1.50	9.21	17.10	31.56	57.84	131.60	210.40	349.60
1058	EARTHSTONE CRANK - ES50	1200-1300	5-10	1.50	11.91	21.44	42.88	76.24	176.20	314.40	572.00
1080	TOASTED STONEWARE	1140-1250	1-8	1.50	8.22	15.26	28.16	51.68	117.40	188.00	312.00
1102	OXIDISING ST THOMAS	1140-1285	1-9	1.50	10.29	17.26	30.12	51.44	124.80	198.40	330.40
1106	WHITE ST THOMAS	1160-1300	3-10	1.50	13.33	23.34	40.00	67.84	161.40	264.80	449.60
1109	FLECKED STONEWARE	1160-1290	3-10	1.50	13.93	22.48	40.08	76.24	182.40	288.40	480.80
1110	THROWER'S MIX	1160-1290	3-10	1.50	13.28	22.14	39.84	75.28	181.60	287.60	469.60
1114	CRAFT CRANK	1170-1300	4-10	1.50	14.74	24.90	42.72	73.20	178.00	282.80	473.60

## White Earthenware/ Stoneware Clays in 12.5kg packs

Code	White E/W - S/W Clay	Maturing Range °C	Cone	Sample	12.5kg	25kg	50kg	100kg	250kg	500kg	1000kg
1040	WHITE RAKU	900-1300*	09-10	1.50	15.25	28.94	54.76	103.20	250.20	453.60	782.40
1044	PEARL WHITE	1130-1270	01-9	1.50	11.77	19.54	34.08	66.16	157.80	295.60	560.80
1070	STUDIO WHITE EARTHENWARE	1100-1220	03-6	1.50	12.24	22.66	39.92	66.32	157.20	277.60	538.40
1081	EARTHSTONE ORIGINAL - ES5	1180-1280	4-9	1.50	12.98	21.44	38.16	72.24	175.00	304.80	582.40
1082	E/S SMOOTH TEXT- ES20	1180-1280	4-9	2.00	18.04	31.42	54.52	104.56	250.00	416.80	801.60
1083	E/S HANDBUILD -ES40	1240-1300	7-10	2.00	16.85	29.22	56.20	104.88	247.20	449.60	764.00

Where the maturing range temperature is followed by \* this indicates a firing range and glaze fit may not be achieved at the lower temperatures.

**We have revised the quantity breaks for clays in 12.5kg packs from 125kg to 100kg.  
Now you can buy just 8 bags and get a cheaper price instead of having to buy 10 bags.**

**In addition to the clays listed we can supply any Potclays, Spencrofts, Valentines & Scarva Clays direct.  
Available only on ¼ mt, ½ mt and 1 mt (pallet) weights. Prices - POA**

## Porcelain Clays in 12.5kg packs

Code	Porcelain Clay	Maturing Range °C	Cone	Sample	12.5kg	25kg	50kg	100kg	250kg	500kg	1000kg
1085	STUDIO PORCELAIN	1220-1280	6-9	2.00	20.16	32.84	48.12	109.52	270.40	436.80	772.80
1149	HF (CRAFT) PORCELAIN	1220-1295	6-10	2.00	21.96	39.54	68.52	116.00	280.20	446.40	744.80
1087	GROGGED PORCELAIN	1220-1300	6-10	2.00	19.86	37.68	69.24	122.24	295.40	468.40	855.20

## Specialist Clays in 12.5kg packs

Code	Specialist Clay	Maturing Range °C	Cone	Sample	12.5kg	25kg	50kg	100kg	250kg	500kg	1000kg
1045	TEXTURED BLACK	1080-1260	03-8	2.00	12.74	24.58	47.32	91.04			
1046	SMOOTH BLACK	1080-1260	03-8	2.00	13.36	25.78	49.64	95.44			

## Specialist Clays in 25kg packs

Code	Specialist Clay	Firing Range °C	Cone	Sample	12.5kg	25kg	50kg	100kg	250kg	500kg	1000kg
1050	T MATERIAL	Over 900°C	09-12	N/A	DISCONTINUED						

## Paper Clays in 5kg packs

Code	Paper Clay	Maturing Range °C	Cone	Sample	5kg	10kg	25kg	50kg	100kg
1180	GROGGED - ES300	1100-1280	03-9	2.50	9.85	17.72	37.55	66.50	127.60
1182	WHITE EARTHENWARE - ES400	1080-1200	03-5	2.50	9.85	17.72	37.55	66.50	127.60
1184	PORCELAIN - ES600	1220-1280	6-9	2.50	13.03	23.58	46.55	83.70	160.60

## Paper Clays in 11kg packs

Code	Paper Clay	Maturing Range °C	Cone	Sample	11kg	22kg	55kg	110kg
1187	WHITE STONWARE	1215-1280	6-9	2.50	18.03	34.00	79.85	149.40
1188	WHITE EARTHENWARE	1080-1150	03-1	2.50	14.07	24.68	58.20	111.80

## Air Drying Clays in 5kg packs

Code	Paper Clay	Maturing Range °C	Cone	Sample	5kg	25kg
1190	AIR DRYING MODELLING CLAY	N/A	N/A	2.50	8.51	34.05

## HELPFUL HINTS!

The firing range details are supplied to aid achieving glaze fit. Fire the clay to a point within the firing range on the bisque or gloss firing to achieve a glaze fit. We normally recommend bisque firing to 1000°C and then glaze fire to a point within the firing range that is also compatible. Exceptions to this rule are 1050 T Material, 1040 White Haze Raku and 1052 Feeney's Buff Mix where the firing range begins at 1000°C as an indicator to their raku properties.

Plastic clays are supplied in polythene sacks. The packs size can be 10kg, 12.5kg or 25kg (T Material only), with wire ties or tape sealed. Clays should be stored in the bags and re-sealed after use away from direct heat and sunlight.

SAMPLES OF ALL CLAYS AVAILABLE FOR £1.50 + VAT (with the exception of T Material)



### HOW GOOD IS THIS?

All bottles, 75ml, 125ml, 250ml and 500ml and jerrycans, 2.5 litres and 5 litres, we sell and use for packaging has the same size screw cap.

# Decorating Slips

## Decorating Slips in liquid

Code	Decorating Slip - Liquid	Firing Range °C	Cone	500ml	5 litres	Trailing Pack
1221	ORCHID WHITE	1110-1300	02-10	3.31	9.59	2.65
1222	SOFT GREEN	1110-1300	02-10	4.04	22.88	3.13
1223	SPECIAL BLUE	1110-1300	02-10	4.23	25.20	3.04
1224	LEMON YELLOW	1110-1300	02-10	4.14	24.11	3.00
1226	JET BLACK	1110-1300	02-10	6.35	38.73	3.94
1227	EARTH RED	1110-1300	02-10	3.43	15.18	2.70
1228	DEEP YELLOW	1110-1300	02-10	4.11	23.70	2.99
1231	CELESTIAL BLUE	1110-1300	02-10	4.82	32.56	3.29
1232	WOODSMAN GREEN	1110-1300	02-10	4.65	30.39	3.22
1233	GOLDEN ORANGE	1110-1300	02-10	5.44	40.35	3.55
1234	THEATRE ROUGE	1110-1300	02-10	6.39	52.18	3.96

## Decorating Slips in powder



Code	Decorating Slip - Powder	Firing Range °C	Cone	500g	2.5kg	5kg	10kg	12.5kg	25kg
1221	ORCHID WHITE	1110-1300	02-10	3.77	12.46	21.80	37.36	44.02	83.64
1222	SOFT GREEN	1110-1300	02-10	4.96	23.10	35.94	61.61	74.31	141.18
1223	SPECIAL BLUE	1110-1300	02-10	5.37	25.40	39.51	67.73	81.97	155.74
1224	LEMON YELLOW	1110-1300	02-10	5.18	24.33	37.84	64.87	78.39	148.94
1226	JET BLACK	1110-1300	02-10	10.03	51.58	80.23	137.54	155.12	282.03
1227	EARTH RED	1110-1300	02-10	3.81	15.48	24.09	41.29	48.92	92.94
1228	DEEP YELLOW	1110-1300	02-10	5.11	23.92	37.21	63.79	77.04	146.37
1231	CELESTIAL BLUE	1110-1300	02-10	6.67	32.69	50.84	87.16	106.25	201.88
1232	WOODSMAN GREEN	1110-1300	02-10	6.29	30.54	47.51	81.45	99.11	188.31
1233	GOLDEN ORANGE	1110-1300	02-10	8.04	40.40	62.84	107.73	131.96	250.73
1234	THEATRE ROUGE	1110-1300	02-10	10.12	52.11	81.06	138.96	171.00	324.90

NOTE: Decorating Slips are available in powder form to enable the user to add water and sieve. Pack size of 2.5kg or more are AVAILABLE TO ORDER ONLY.

## HELPFUL HINTS!

Although all decorating slips are developed to fire through the earthenware and stoneware firing range, our slips are **best used at earthenware temperatures**. The colours will weaken in the stoneware range. Best results are achieved using our decorating slips with glazes such as 2201 Low-sol Transparent, 2207 Spring Clear or 2800 Traditional Honey.

Coloured decorating slips can be made easily by adding Rainbow Multi-colours to Orchid White Slip in powder form. For ease take a 25g jar of colour and add to 250g of powdered slip.

Our Decorating Slips in liquid form are supplied to a consistency ready for dipping. Water can be removed to adjust for individual needs. The Trailing Pack consistency has been adjusted to enable trailing from the pack after shaking.



Rowena Gilbert Contemporary Ceramics. Vessels are slipcast using pearl white casting slip. The layers of blue and white slip (orchid white decorating slip, and orchid white slip with addition of cobalt) are brushed on then scraped through to produce the linear design. [www.rowenagilbert.com](http://www.rowenagilbert.com)

# Casting Slips

## Standard Casting Slips

Code	Casting Slip - Standard	Firing Range °C	Cone	5 litres	5 x 5 litres	Comments
1430	REALLY GOOD STONEWARE	1180-1280	5-9	8.47	40.95	Made from 1038 plastic body
1440	STUDIO PORCELAIN	1230-1280	6-9	18.47	89.30	Made from 1085 plastic body
1450	BONE CHINA	1200-1250	5-8	20.62	99.65	Made from 1068 plastic body
1465	PARIAN BODY	1200-1240	5-7	27.06	130.75	Self glazing and translucent specialist body
1480	TERRACOTTA	1020-1180	05-4	7.95	37.20	Made from 1020 plastic body
1485	PEARL WHITE	1130-1270	01-9	10.71	50.10	Made from 1044 plastic body

## Hobby Casting Slips

Code	Casting Slip - Hobby	Firing Range °C	Cone	5 litres	5 x 5 litres	Comments
1474	ULTRA WHITE	1000-1060	06-04	8.42	28.10	A superb white quick casting slip

## Paperclay Pouring Slips

Code	Casting Slip - Paperclay	Firing Range °C	Cone	5 litres	Comments
1417	PORCELAIN	1220-1280	6-9	16.46	
1418	WHITE EARTHENWARE	1080-1200	03-5	14.04	

All castings slips are packed in 5 litre buckets with carrying handles. When these are sent by carrier we re-pack these slips into 5 litre jerrycans which travel much better. This incurs a re-packaging charge of £1.75 + vat. when casting slips are included in orders that are palletised the re-packaging is not necessary.

## Hobby Casting Slip - Powder

Code	Casting Slip - Powder	Firing Range °C	Cone	25kg	50kg	125kg	250kg	500kg	1000kg
1474	ULTRA WHITE	1000-1060	06-04	22.30	40.68	94.20	173.90	327.20	595.60

## HELPFUL HINTS!

Casting Slips are produced by adding deflocculant and water to plastic or powdered clay. Too much deflocculant can cause cracking or sticking in the mould. Too little or under-deflocculation is sometimes desired but causes thickening of the slip, but the slip will thin on stirring or shaking (i.e. thixotropic). Sodium Silicate and Soda Ash are often used as deflocculents, but we recommend Sodium Dispex as a slip reviver. Add cautiously should your slip thicken after use.

## 9700 - SLIPCASTING

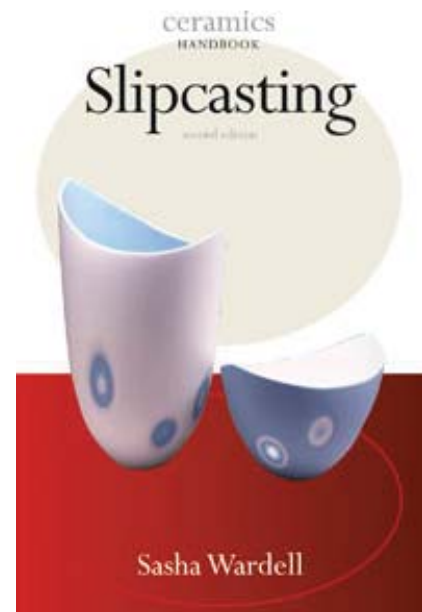

An excellent book to acquire if you are starting out casting.  
Just £15.99

# Glazes (Powdered, Brush-on & Dipping)

## Raku

Code	Raku	Firing Range °C	Cone	125ml	500ml	2.5 litre	500g	2.5kg	5kg	10kg	12.5kg	25kg	5 litres
				Brush-on			Powder						Dipping
2100	TRANSPARENT	960-1020	07-04	3.21	9.25	28.43	3.83	14.29	26.38	48.36	-	-	
2101	CRACKLE WHITE	960-1040	07-05	3.38	9.91	32.77	9.06	41.81	77.18	141.52	-	-	
2102	TURQUOISE	960-1020	07-04	3.28	9.85	31.28	6.10	24.82	45.82	84.00	-	-	

## Transparent

Code	Transparent	Firing Range °C	Cone	125ml	500ml	2.5 litre	500g	2.5kg	5kg	10kg	12.5kg	25kg	5 litres
				Brush-on			Powder						Dipping
2201	LOW-SOL TRANSPARENT (Low-solubility)*	1020-1130	05-01	4.22	13.26	45.66	4.06	19.54	35.44	62.52	75.71	121.14	
2206	SEMI-TRANSPARENT MATT (Leadless)	1040-1120	05-01	3.92	12.05	41.49	4.63	21.44	38.10	66.68		127.68	
2207	SPRING CLEAR (Unleaded)	1040-1150	05-2	3.95	12.20	41.67	4.15	20.63	39.80	68.04	79.96	131.49	

## Opaque

Code	Opaque	Firing Range °C	Cone	125ml	500ml	2.5 litre	500g	2.5kg	5kg	10kg	12.5kg	25kg	5 litres
				Brush-on			Powder						Dipping
2203	GLOSS WHITE TIN (Unleaded)	1040-1120	05-01				6.87	33.75	62.32	114.25	127.58	199.02	
2204	VELLUM WHITE MATT (Low-solubility)*	1020-1110	05-01	4.71	13.81	48.13	6.67	32.66	60.30	110.56	123.37	217.14	
2205	GLOSS WHITE ZIRCON (Unleaded)	1030-1120	05-01				6.00	24.40	45.04	82.56	91.59	161.20	
2208	SNOW WHITE (Leadless)	1040-1150	05-01	3.81	11.63	37.59	5.20	20.65	38.13	69.91	77.19	135.85	
2212	WHITE EGGSHHELL MATT (Low-solubility)*	1040-1150	05-01	3.79	11.54	39.03	11.76	51.13	94.40	173.04	194.40	342.15	

## Carnival Opaque & Semi-Opaque

Code	Carnival Opaque & Semi-opaque	Firing Range °C	Cone	125ml	500ml	2.5 litre	500g	2.5kg	5kg	10kg	12.5kg	25kg	5 litres
				Brush-on			Powder						Dipping
2302	HONEY BROWN (Unleaded)	1020-1120	05-01	2.78	7.50	23.49	4.92	24.93	46.30	85.48	86.79	152.75	
2305	CITRUS YELLOW (Unleaded)	1020-1120	05-01	3.70	11.19	37.69	6.58	32.15	59.36	108.80	120.90	212.79	
2306	LEATHER GREEN (Unleaded)	1020-1120	05-01	3.64	10.95	36.77	6.30	30.66	56.60	103.76			
2307	MIDNIGHT BLUE (Unleaded)	1020-1120	05-01	4.13	12.89	44.24	6.60	32.28	59.58	109.24			
2308	RAVEN BLACK (Unleaded)	1020-1120	05-01	4.14	12.97	44.53	8.77	44.04	81.32	149.08			
2309	CRIMSON (Unleaded)	1020-1120	05-01	4.41	14.05	48.68	9.82	49.70	91.74	168.20			
2310	JADE GREEN (Unleaded)	1020-1120	05-01	3.67	11.06	37.19	6.30	30.65	56.58	103.72			
2311	PEPPERMINT GREEN (Unleaded)	1020-1120	05-01	3.71	11.23	37.83	6.50	31.71	58.54	107.32			
2312	LILAC BLUE (Unleaded)	1020-1120	05-01	4.69	15.15	52.90	10.96	55.88	103.16	189.16			
2314	LAVENDER (Unleaded)	1020-1120	05-01	3.69	12.28	61.12	9.82	49.71	91.78	168.28			
2315	TURQUOISE BLUE (Unleaded)	1020-1120	05-01	3.69	11.14	37.51	6.53	31.89	58.86	107.92			
2322	LEATHER BROWN (Unleaded) +	1020-1120	05-01	4.10	10.85	36.37	6.15	29.84	55.09	101.01			
2323	POWDER PINK+	1020-1120	05-01	5.14	16.93	59.78	7.03	33.99	62.76	115.04			
2324	SALMON RED+	1020-1120	05-01	3.88	11.90	40.43	7.29	36.02	66.49	121.90			
2325	WALNUT BROWN (Unleaded) +	1020-1120	05-01	3.55	10.60	40.43	5.76	27.73	54.24	93.86			
2326	STEEL GREY (Unleaded) +	1020-1120	05-01	3.59	10.97	36.00	6.07	29.38	54.24	99.44			
2327	EVERGREEN (Unleaded) +	1020-1120	05-01	3.64	10.97	36.00	6.19	30.07	55.52	101.80			
2329	PILLAR BOX RED (Unleaded) +	1020-1120	05-01	4.36	13.83	47.82	9.55	48.27	89.12	163.40			
2330	MARIGOLD (Unleaded) +	1020-1120	05-01	3.90	11.98	40.74	7.36	36.37	67.14	123.08			
2332	MINT GREEN (Unleaded) +	1020-1120	05-01	3.54	10.54	35.19	5.58	26.73	49.36	90.48			
2333	TANGERINE (Unleaded) +	1020-1120	05-01	3.90	11.98	40.74	7.49	37.07	68.44	125.48			

Note: All 2.5 litre pack sizes of brush-on glaze are to order only. Glazes marked + are made to order in powder form. Time delay 3-4 days. Dipping glazes marked \*\* are to order only.

## OXIDISED & REDUCTION FIRINGS

All glazes supplied have been formulated for oxidised firings. Some may also be used in reduction firings such as our raku glazes. The only stoneware glazes that we have tested in reduction atmospheres are 2503 Stoneware Transparent (becomes silver grey) and 2910 Sand Green (celadon).

## RUBBER KIDNEY SET

Three flexible rubber kidneys, small, medium and large, bundled into a set to offer amazing value.

ONLY  
£5.34 + VAT



## Studio Earthenware

Code	Studio Earthenware	Firing Range °C	Cone	125ml	500ml	2.5 litre	500g	2.5kg	5kg	10kg	12.5kg	25kg	5 litres
2800	TRADITIONAL HONEY (Low-solubility)*	1080-1120	03-01	3.30	9.58	31.49	6.58	32.15	59.36	108.80	145.69	287.10	Dipping
2801	ROCKINGHAM BROWN (Low-solubility)*	1020-1120	05-01	3.29	9.46		4.58	19.80	36.22	63.68		128.55	

Note: All glazes followed by \* are labelled "TOXIC"

## Super Coloured Earthenware

Code	Super Coloured Earthenware	Firing Range °C	Cone	125ml	500ml	2.5 litre	500g	2.5kg	5kg	10kg	12.5kg	25kg	5 litres
2400	VAMPIRE RED*	960-1070	06-04	6.00	15.51	64.64	14.76	71.87	131.76	239.56			Dipping
2401	OLD GOLD*	1000-1060	06-04	4.54	14.57	40.54	7.66	35.90	65.80	119.64			
2405	METALLIC GOLD*	1020-1080	05-04	CURRENTLY UNAVAILABLE - NEAREST ALTERNATIVE 2401 OLD GOLD									
2406	PEACOCK*	1020-1080	05-04	5.22	17.28	48.88	6.56	30.12	55.22	100.41			
2408	SPARKLING YELLOW*	960-1070	06-04	5.52	14.07	58.24	12.73	62.27	114.16	207.56			
2409	SIZZLING ORANGE*	960-1070	06-04	5.76	14.79	61.44	13.79	66.92	122.68	223.04			
2411	DARK SILVER*	1020-1080	05-04	5.24	14.69	68.08	4.96	22.90	41.98	76.32			

Note: All glazes followed by \* are labelled "TOXIC"

## Mid-Range Stoneware

Code	Mid-range Stoneware	Firing Range °C	Cone	125ml	500ml	2.5 litre	500g	2.5kg	5kg	10kg	12.5kg	25kg	5 litres
2450	SATIN WHITE*	1120-1240	01-6	Brush-on			Powder						Dipping
2451	DOVE GREY*	1120-1240	01-6				7.75	39.06	72.12	132.31			
2452	MOTTLED WHITE*	1120-1250	01-8	3.94	12.13	41.32	5.67	25.12	46.37	85.01			
2500	TURQUOISE MATT	1200-1270	5-9	4.29	13.56	46.81	5.75	28.14	52.59	93.90	137.25		
2501	MOTTLED MAIZE	1200-1270	5-9				5.89	28.89	52.97	96.30	141.00		
2502	MISTY BLUE	1200-1270	5-9				4.21	19.74	36.19	65.80	95.25		
2503	STONWARE TRANSPARENT	1180-1270	5-9	2.96	8.21	26.24	3.65	15.20	26.75	52.29	64.90	84.08	
2506	WHITE FROST	1180-1270	5-9	3.64	10.95	36.76	4.10	19.13	35.08	63.76	92.22		

Note: All glazes followed by \* are labelled "TOXIC"

## Standard Stoneware

Code	Standard Stoneware	Firing Range °C	Cone	125ml	500ml	2.5 litre	500g	2.5kg	5kg	10kg	12.5kg	25kg	5 litres
2607	BLUE GREY	1230-1280	6-9	Brush-on			Powder						Dipping
2609	LIGHT OATMEAL	1230-1280	6-9	2.87	7.89	25.00	2.46	10.90	19.80	33.56	40.19		
2611	GREEN MAGNETITE	1230-1280	6-9				2.04	8.87	16.10	27.32	32.38		
2612	SEMI-TRANSPARENT MATT	1230-1280	6-9				2.59	11.54	20.94	35.52	44.88		
2614	TENMOKU	1280-1300	9-10				4.67	20.75	36.26	61.56			
2615	SATIN OFF-WHITE MATT	1260-1290	8-10				2.72	13.70	24.90	44.84	60.00		
2616	SATIN BLUE DOLOMITE MATT	1260-1290	8-10				3.51	18.78	34.16	61.48	83.13		
2616	SATIN BLUE DOLOMITE MATT	1260-1290	8-10				3.69	19.88	36.16	65.08	88.13		
2617	CRYSTAL BROWN MATT	1220-1260	6-9				2.46	12.39	22.52	40.56	54.06		
2618	BLUE LAGOON (FJORD)	1220-1260	6-9				7.89	37.01	54.78	104.80	127.97		
2619	LICHEN GREEN	1260-1290	8-10				6.08	30.75	55.90	100.64	137.50		
2620	CHUN BASE	1220-1260	6-9				4.44	19.54	35.52	63.96	86.56		
2621	COPPER CHUN	1220-1260	6-9				4.36	28.78	45.20	87.64	93.16		
2622	COBALT CHUN	1220-1260	6-9				4.46	24.96	46.34	85.56	95.56		
2623	IRON CHUN	1220-1260	6-9				4.30	23.99	44.56	82.26	91.78		
2624	TIVOLI RED	1220-1260	6-9				5.73	33.09	56.74	107.80	127.53		
2625	DRY PEPPER	1200-1260	5-9				3.25	17.28	32.04	59.16	65.31		
2626	NEVADA RED	1220-1260	6-9				4.22	23.47	43.58	80.48	89.72		
2627	JUPITER BLUE	1180-1260	4-8				4.21	23.38	43.42	80.16	89.38		
2628	TRANSPARENT MATT	1180-1260	4-8				2.68	13.67	25.38	46.88	55.88		
2631	TOPAZ	1230-1280	6-9				3.71	17.87	33.18	61.28	63.38		

## Studio Stoneware

Code	Studio Stoneware	Firing Range °C	Cone	125ml	500ml	2.5 litre	500g	2.5kg	5kg	10kg	12.5kg	25kg	5 litres
2900	MATT DOLOMITE	1230-1260	6-8	Brush-on			Powder						Dipping
2903	TENMOKU - OXIDISED	1240-1290	7-10				1.68	7.79	13.82	25.92	27.10	46.46	
2904	SIERRA RED	1230-1280	6-9	2.98	8.30	26.57	2.43	13.44	23.90	44.80	49.12	84.20	
2910	SAND GREEN	1230-1290	6-10				1.67	10.24	19.62	35.84	43.87	83.92	
2913	WINE BOTTLE GREEN	1230-1290	6-10	3.19	9.17	29.63	2.09	10.83	19.26	36.08	38.96	66.80	
2915	MUSHROOM	1230-1280	6-9	2.97	8.26	26.43	2.74	14.01	26.28	49.05	54.01	99.72	
2917	ELECTRIC BLUE	1230-1290	6-10	2.97	8.26	26.43	1.52	8.83	16.92	30.88	37.12	67.78	
2918	GLOSS WHITE	1230-1280	6-9	4.24	13.35	45.98	6.28	32.88	61.06	112.72	138.22	253.40	
2918	GLOSS WHITE	1230-1280	6-9	3.14	8.96	29.12	5.31	23.36	42.82	77.88	114.10	209.18	
2927	WHITE HOT	1230-1290	6-10	4.57	14.65	51.01	7.99	39.27	72.94	134.64	165.61	303.62	

## Porcelain Glass

Code	Porcelain Glass	Firing Range °C	Cone	125ml	500ml	2.5 litre	500g	2.5kg	5kg	10kg	12.5kg	25kg	5 litres
2710	GLOSS TRANSPARENT	1240-1300	7-10	Brush-on			Powder						Dipping
				3.88	11.92	40.51	4.61	21.92	40.18	73.04			

# Chrysanthos Brush-on-Glazes

## Superior



Code	Superior	140ml	500ml	5 litres
<i>Firing Range: 1000-1101°C (Cone 06-03)</i>				
SG001	WHITE	3.46	10.21	31.96
SG009	IVORY	3.46	10.21	
SG013	APRICOT	3.46	10.21	
SG025	PEACH	3.46	10.21	
SG033	CORAL ORANGE	3.46	10.21	
SG037	DEEP MANDARIN	3.46	10.21	
SG041	PUMPKIN	3.46	10.21	
SG045	ROSE QUARTZ PINK	3.46	10.21	
SG057	DUSKY PINK	3.46	10.21	
SG061	DAFFODIL	3.46	10.21	
SG065	CITRUS	3.46	10.21	
SG073	DEEP RED	3.46	10.21	
SG081	PRISM RED	3.46	10.21	
SG085	GOLD BROWN	3.46	10.21	
SG087	MEDIUM BROWN	3.46	10.21	
SG089	PASTEL MAUVE	3.46	10.21	
SG093	PASTEL LAVENDER	3.46	10.21	
SG097	ORCHID	3.46	10.21	
SG101	WISTERIA	3.46	10.21	
SG109	ROYAL PURPLE	3.46	10.21	
SG113	REGENCY PURPLE	3.46	10.21	
SG121	BURGUNDY	3.46	10.21	
SG125	ART GREY	3.46	10.21	
SG129	LIGHT JADE	3.46	10.21	
SG133	PARIS GREEN	3.46	10.21	
SG137	APPLE GREEN	3.46	10.21	
SG141	JASPER	3.46	10.21	
SG149	JADE GREEN	3.46	10.21	
SG153	LEAF GREEN	3.46	10.21	
SG155	MEDIUM GREEN	3.46	10.21	
SG157	CHROME GREEN	3.46	10.21	
SG161	LIGHT PEACOCK	3.46	10.21	
SG165	PEACOCK	3.46	10.21	
SG169	TURQUOISE	3.46	10.21	
SG173	TUSCANY BLUE	3.46	10.21	
SG177	MAUVE	3.46	10.21	
SG181	COUNTRY BLUE	3.46	10.21	
SG185	BARRIER REEF BLUE	3.46	10.21	
SG189	FEDERAL BLUE	3.46	10.21	
SG193	TEAL	3.46	10.21	
SG197	COBALT BLUE	3.46	10.21	
SG204	ANTIQUÉ BROWN	3.46	10.21	
SG209	EBONY	3.46	10.21	
SG213	CLEAR	1.44	5.04	27.69

## Crystallite



Code	Crystallite	140ml
<i>Firing Range: 1000-1101°C (Cone 06-03)</i>		
CR001	WHITE	2.94
CR005	BRIGHT YELLOW	2.94
CR013	PERSIMMION	2.94
CR017	CORAL RED	2.94
CR025	BURGUNDY	3.61
CR029	JASPER	2.80
CR033	JADE GREEN	2.94
CR037	APPLE	2.94
CR041	BRUNSWICK GREEN	2.94
CR049	SUMMER BLUE	3.54
CR053	COBALT BLUE	2.94
CR057	IRIS PURPLE	4.03
CR061	GREY	2.94
CR065	TERRACOTTA	3.29
CR069	COBALT BLACK	2.94

## Fantasy



Code	Fantasy	140ml	500ml
<i>Firing Range: 1000-1101°C (Cone 06-03)</i>			
FG001	RHUBARB	4.62	14.00
FG003	DALMATION	4.62	14.00
FG006	BLUE EYES	4.62	14.00
FG034	BUMBLE BEE	4.62	14.00
FG036	LEMONCELLO	4.62	14.00
FG037	VERMILLION SUNBURST	4.62	14.00
FG039	AYERS ROCK	4.62	14.00
FG055	FAIRY FLOSS	4.62	14.00
FG057	ORIENTAL PRINCESS	4.62	14.00
FG081	FUCHSIA FANTASTIC	4.62	14.00
FG084	LADY BIRD	4.62	14.00
FG121	WINE FIESTA	4.62	14.00
FG124	BERRY GOOD	4.62	14.00
FG135	BILLABONG	4.62	14.00
FG137	GIDDY GRAPE	4.62	14.00
FG139	JURASSIC	4.62	14.00
FG141	ENVY	4.62	14.00
FG155	CHROMIUM	4.62	14.00
FG167	EMERALD ORIUM	4.62	14.00
FG169	NEPTUNE	4.62	14.00
FG175	ROYAL AMETHYST	4.62	14.00
FG177	MAUVIANCE	4.62	14.00
FG179	TRANQUILITY	4.62	14.00
FG181	AURORA	4.62	14.00
FG183	NEBULA	4.62	14.00
FG185	DELPHINIUM	4.62	14.00
FG190	MURANO	4.62	14.00
FG200	COSMOS	4.62	14.00
FG207	ABYSS	4.62	14.00
FG209	EBONISER	4.62	14.00

## Fantasy Crystals



Code	Fantasy Crystals	50g
<i>Firing Range: 1000-1060°C (Cone 06-04)</i>		
FC001	CLEAR	3.26
FC005	WHITE	3.26
FC010	YELLOW	3.26
FC013	ORANGE	3.26
FC015	RED	3.26
FC016	VIOLET	3.26
FC021	GREEN	3.26
FC025	BLUE	3.26
FC027	COPPER	3.26
FC029	BLACK	3.26

## Fantasy Glaze & Crystal Additions

Code	Fantasy Glaze & Crystal Additions	140ml	500ml
<i>Firing Range: 1000-1060°C (Cone 06-04)</i>			
SP0225	FANTASY ENHANCER	7.47	16.30

## Feng Shui

Code	Feng Shui	140ml	500ml
<i>Firing Range: 1000-1060°C (Cone 06-04)</i>			
FS067	CADMIUM YELLOW	3.64	11.97
FS079	TORO RED	3.64	11.97
FS157	FEICUI LU (EMERALD GREEN)*	2.91	8.72
FS201	BRONZE METAL*	5.04	13.75
FS205	GUN METAL*	5.04	13.75

Note: All glazes followed by \* contain lead.

## Hobby

Code	Hobby	Firing Range °C	Cone	140ml	500ml	5 litres	10 litres
HG001	CLEAR* (Low-sol) - Brush-on	1000-1101	06-03	2.56	5.92	29.51	Dipping
HC005	CLEAR* (Low-sol) - Dipping						44.10
SG213	LEADFREE CLEAR - Brush-on	1000-1101	06-03	1.44	5.04	27.69	
SG216	LEADFREE CLEAR - Dipping	1000-1101	06-03				44.10

Note: All glazes followed by \* are labelled "TOXIC"

### 3D Trailing Glazes

Code	3D Trailing Glazes	40ml	500ml
<i>Firing Range: 1000-1101°C (Cone 06-03)</i>			
3D005	YELLOW	2.31	19.68
3D009	ORANGE	2.31	19.68
3D013	RED	2.31	19.68
3D017	GREEN	2.31	19.68
3D021	BLUE	2.31	19.68
3D025	BLACK	2.31	19.68

### Chrysanthos Crackle Glazes

Code	Chrysanthos Crackle Glazes	140ml	500ml
<i>Firing Range: 1000-1101°C (Cone 06-03)</i>			
CG001	CLEAR	3.81	9.24
CG003	WHITE	3.50	
CG005	CELADON	3.90	8.09
CG007	GREEN	3.12	8.02
CG009	EGYPTIAN BLUE	4.29	9.49
CG011	BLUE LAGOON	3.48	11.90
CG013	ITALIAN BLUE	4.29	9.49

### High Fire

Code	High Fire	140ml	500ml
<i>Firing Range: 1186-1222°C (Cone 4-6)</i>			
HF001	WHITE	3.68	10.92
HF005	IVORY	3.68	10.92
HF009	CITRUS	3.68	10.92
HF013	PUMPKIN	3.68	10.92
HF021	MANDARIN	3.68	10.92
HF041	PRISM RED	3.68	10.92
HF045	CRIMSON	3.68	10.92
HF053	ROSE PINK	3.68	10.92
HF073	MAUVE	3.68	10.92
HF093	YELLOW GREEN	3.68	10.92
HF097	GREEN	3.68	10.92
HF101	LIGHT JADE	3.68	10.92
HF105	JADE	3.68	10.92
HF121	SUNSET BLUE	3.68	10.92
HF129	BRIGHT BLUE	3.68	10.92
HF141	GOLD BROWN	3.68	10.92
HF145	ANTIQUE BROWN	3.68	10.92
HF149	GREY	3.68	10.92
HF153	COBALT BLACK	3.68	10.92
HF157	CLEAR	1.79	5.32

### High Fire Exotics

Code	High Fire Exotics	140ml	500ml
<i>Firing Range: 1186-1220°C (Cone 4-6)</i>			
HE001	BRONZE METAL	6.63	18.46
HE005	GUN METAL	6.63	18.46
HE109	ORANGE ONYX	4.24	13.39
HE113	POMEGRANATE	4.24	13.39
HE117	SEA SPRAY	4.24	13.39
HE133	GREEN AGATE	4.24	13.39
HE141	MARBLE BROWN	4.24	13.39
HE149	BLUE AGATE	4.24	13.39
HE201	LOW SHEEN CLEAR	2.48	7.95
HE301	CRACKLE CLEAR	2.48	7.95

### Low Sheen Glazes

Code	Low Sheen Glazes	140ml
<i>Firing Range: 1000-1060°C (Cone 04-06)</i>		
LS001	WHITE	4.90
LS013	LEMON YELLOW	4.90
LS017	ORANGE	4.90
LS021	PRISM RED	4.90
LS041	GREEN	4.90
LS057	PRISM BLUE	4.90
LS069	BLACK	4.90
LS073	CLEAR	2.76

### 6231 - MODELLING TOOL SET



When budget is important and you need modelling tools that will last, try this set of four 180mm long plastic modelling tools.

Just £1.05 + vat

## The Shimpo RK55 Potters Wheel

A new "budget" wheel from Shimpo.



- Up to 12kg centring capacity
- Three-leg design increases stability.
- Built-in worktable for tools and pots.
  - Two-Piece Splashpan
  - Remote foot pedal
- Modular design for compact storage.
  - 1.8m power supply cord
- Two Year Warranty for Peace of mind.

Motor: 1/8 HP 100W

Drive System: DC Motor with Brush

Wheelhead Speed: 0-250RPM

Wheelhead Direction: Clockwise/counter

Wheelhead: 300mm/12" light alloy casting

Dimension: W560 x D720 x H540mm

Weight 23kg

**JUST £499.00 + VAT**

# Colours

## Underglaze Pencils

Code	Underglaze Pencils	Firing Range °C	Cone	Each
3000	BLACK	Up to 1280	9	6.98
3001	OLIVE GREEN	Up to 1280	9	6.98
3002	BOTTLE GREEN	Up to 1280	9	6.98
3003	BROWN	Up to 1280	9	6.98
3004	LIGHT BROWN	Up to 1280	9	6.98
3005	CRIMSON	Up to 1060	04	6.98
3006	YELLOW	Up to 1060	04	6.98
3007	PURPLE	Up to 1060	04	6.98
3008	BLUE	Up to 1280	9	6.98
3009	AZURE BLUE	Up to 1280	9	6.98
3010	PEACOCK BLUE	Up to 1280	9	6.98
3011	RED	Up to 1060	04	6.98

## Rainbow Multi-colours - Underglaze, Glaze & Body Stains

Code	Rainbow Multi-colours	Firing Range °C	Cone	25g	100g	500g
3170	LIME GREEN	1000-1300	06-10	1.90	4.04	15.66
3171	VICTORIA GREEN	1000-1300	06-10	2.13	4.69	18.59
3172	TURQUOISE GREEN	1000-1300	06-10	1.96	4.19	16.56
3173	TURQUOISE BLUE	1000-1300	06-10	1.86	3.91	15.11
3174	CORNFLOWER BLUE	1000-1300	06-10	2.99	7.15	29.66
3176	CRIMSON	1000-1150	06-1	2.73	6.41	26.33
3177	TAN PINK	1000-1300	06-10	1.99	4.30	16.84
3178	DEEP ORANGE	1000-1300	06-10	1.98	4.27	16.70
3179	CANARY YELLOW	1000-1300	06-10	1.82	3.81	14.66
3180	AUTUMN BROWN	1000-1300	06-10	2.08	4.55	17.98
3182	MID-GREY	1000-1300	06-10	1.95	4.18	16.29
3183	CARBON BLACK	1000-1300	06-10	2.76	6.24	25.58
3184	DEEP PURPLE	1000-1150	06-1	2.79	6.57	27.05
3186	FOREST GREEN	1000-1300	06-10	2.05	4.45	17.51
3187	SIENNA BROWN	1000-1300	06-10	2.29	5.16	20.70
3200	LAVENDER	1000-1150	06-10	3.21	7.76	32.43
3201	ROSE PINK	1000-1150	06-1	2.79	6.59	27.14
3211	BUFFALO BROWN	1000-1300	06-10	1.87	3.95	15.28
3212	SEPIA BROWN	1000-1300	06-10	1.71	3.50	13.24
3214	WHITE	1000-1300	06-10	2.04	4.42	17.39
3215	LIGHT GREY	1000-1300	06-10	1.78	3.70	14.13
3216	JUNIPER GREEN	1000-1300	06-10	2.09	4.58	18.09
3217	BRAMLEY GREEN	1000-1300	06-10	1.90	4.03	15.62
3218	MIDNIGHT BLUE	1000-1300	06-10	2.20	4.90	19.53
3219	MAZARINE BLUE	1000-1300	06-10	2.36	5.34	21.53
3226	CORN YELLOW	1000-1300	06-10	2.08	4.55	17.98
3227	VIOLET BLUE	1000-1300	06-10	2.38	5.39	21.77
3229	DENIM BLUE	1000-1300	06-10	3.22	7.81	32.66
3231	RIVIERA BLUE	1000-1300	06-10	1.86	3.93	15.17
3232	SEA GREEN	1000-1300	06-10	2.01	4.35	17.08
3233	EMERALD GREEN	1000-1300	06-10	DISCONTINUED		
3234	SPRING GREEN	1000-1300	06-10	1.90	4.02	15.60
3235	HOLLY GREEN	1000-1300	06-10	1.84	3.87	14.91

Code	Accessories	Firing Range °C	Cone	25g	100g	500g
3981	U/G FLUX (Low-sol)	1000-1300	06-10	1.51	3.68	11.34
3982	U/G FLUX (Leadless)	1000-1300	06-10	1.28	2.00	7.66

## Ultra Stains - Underglaze, Glaze & Body Stain

Code	Ultra Stains	Firing Range °C	Cone	100g	500g
3460	VOLCANIC BLACK*	1000-1300	06-10	9.73	40.81
3461	GALAXY BLUE	1000-1300	06-10	6.66	27.23
3462	SPICE BROWN	1000-1300	06-10	1.95	6.10
3463	BURGUNDY	1000-1300	06-10	3.49	13.21
3464	EVERGREEN	1000-1300	06-10	2.92	10.64
3465	ROASTED PEACH	1000-1300	06-10	2.39	8.27
3466	JADE	1000-1300	06-10	4.03	15.64
3467	RUBY	1000-1300	06-10	3.52	13.35
3468	CHILLI RED	1000-1300	06-10	7.30	30.34
3469	RICH TURQUOISE	1000-1300	06-10	2.54	8.78
3470	GRAPE PURPLE	1000-1300	06-10	9.74	41.31
3471	COBALT BLUE	1000-1300	06-10	8.60	36.19
3472	SUNFLOWER	1000-1300	06-10	2.08	6.68
3473	MARIGOLD	1000-1300	06-10	4.53	17.88
3474	BRILLIANT ORANGE	1000-1300	06-10	6.08	24.85
3475	ABSOLUTE RED	1000-1300	06-10	4.98	19.92
3476	STEEL GREY	1000-1300	06-10	5.69	23.10

Note: All colours followed by \* are labelled "TOXIC"



'Rose Studded Heart Soap Dish' and 'Rose Studded Teapot 'Silver Dots' with Crown' by Mary Rose Young using Clayman Ultra Stains Range. <http://maryroseyoung.com>

## Velvet Underglaze

Code	Velvet Underglaze	59ml	473ml
<i>Firing Range: 1000-1220°C (Cone 06-6)</i>			
V303	TERRACOTTA	4.10	18.32
V304	STRAW	4.10	
V308	YELLOW	4.10	17.97
V309	DEEP YELLOW	4.10	17.97
V310	TAN	4.14	-
V313	RED BROWN	4.10	17.97
V314	CHOCOLATE BROWN	4.10	17.97
V315	PEACH	4.56	-
V317	MEDIUM PINK	DISCONTINUED	
V318	ROSE	4.56	20.23
V320	LAVENDER	6.58	45.00
V321	LILAC	4.54	20.23
V322	PURPLE	4.67	20.23
V325	BABY BLUE	4.10	17.97
V326	MEDIUM BLUE	4.10	17.97
V327	TURQUOISE BLUE	4.10	17.97
V332	TEALE BLUE	4.10	17.97
V333	AVOCADO	4.10	17.97
V336	ROYAL BLUE	6.69	-
V341	BLUE GREEN	4.31	19.71
V343	CHARTREUSE	4.10	17.97
V345	LIGHT GREEN	4.10	-
V350	ORANGE	4.10	17.97
V353	DARK GREEN	4.10	17.97
V354	LEAF GREEN	4.10	17.97
V355	SHADOW GREEN	4.10	-
V356	PEARL GREY	4.10	-
V357	DARK GREY	4.10	-
V360	WHITE	4.10	17.97
V361	JET BLACK	4.10	17.97
V366	TEDDY BEAR BROWN	4.10	-
V367	MIST GREY	4.10	-
V370	VELOUR BLACK	4.67	20.23
V373	MEDIUM BROWN	4.10	-
V374	ROYAL PEACH	4.10	-
V375	MAROON	6.69	-
V376	HUNTER GREEN	4.10	-
V380	VIOLET	6.82	42.32
V381	AMETHYST	6.82	41.65
V382	RED	7.22	67.25
V383	LIGHT RED	7.22	45.00
V384	REAL ORANGE	7.22	45.00
V385	CINNAMON	4.10	-
V386	ELECTRIC BLUE	4.10	-
V387	BRIGHT RED	7.22	45.00
V388	RADIANT RED	7.22	45.00
V389	FLAME RED	7.22	45.00
V390	BRIGHT ORANGE	7.22	45.00
V391	INTENSE YELLOW	7.22	45.00



Thrown porcelain bowl using Amaco Velvets for decoration by Peter Lane  
[www.studio-porcelain.co.uk](http://www.studio-porcelain.co.uk)

## Amaco Velvet Underglazes

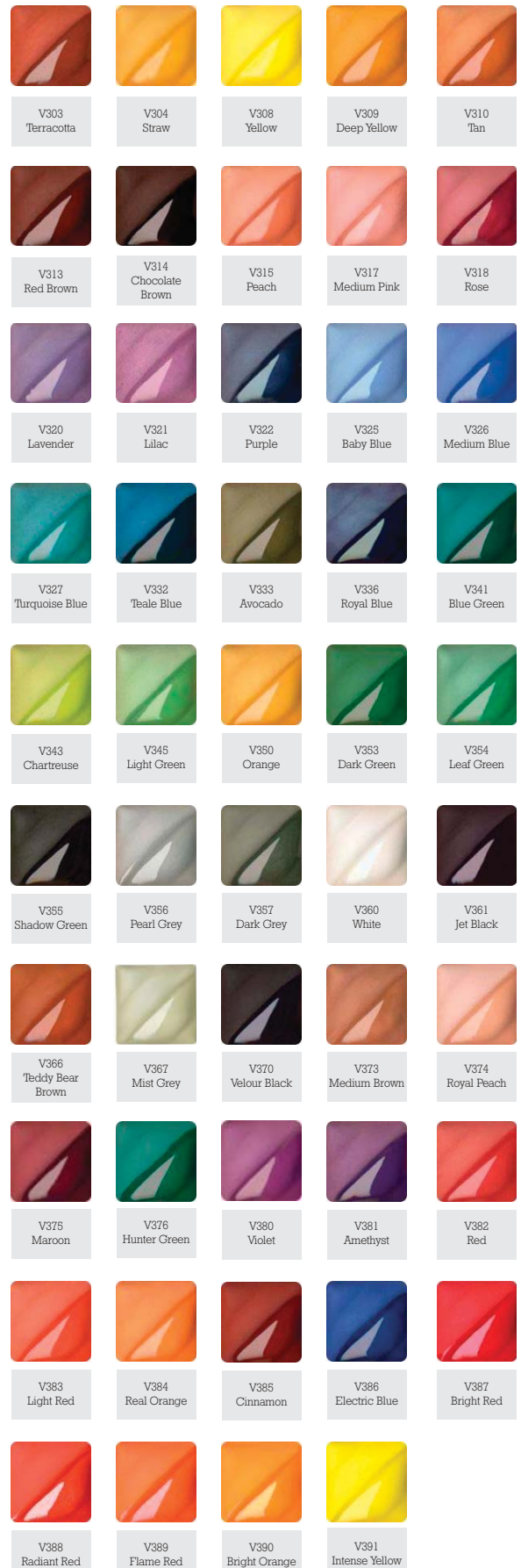

# Chrysanthos Colours

## Chrysanthos Underglaze



Code	Chrysanthos Underglaze	60ml	500ml
<i>Firing Range: 1000-1300°C (Cone 06-10) unless specifically detailed</i>			
UG001	WHITE - (1000-1300°C - Cone 06-10)	2.15	10.23
UG005	CANARY YELLOW - (1000 - 1250°C - Cone 06-8)	2.15	10.23
UG009	BRIGHT YELLOW -	2.15	10.23
UG013	CITRUS	2.15	10.23
UG021	FLESH	2.15	10.23
UG025	BEIGE	2.15	10.23
UG029	PEACH - (1000 - 1250°C - Cone 06-8)	2.15	10.23
UG033	APRICOT	2.15	10.23
UG037	BURNT ORANGE	2.15	10.23
UG041	SAFFRON	2.15	10.23
UG045	MELON	2.15	10.23
UG049	MANDARIN	2.15	10.23
UG061	CORAL PINK - (1000 - 1220°C - Cone 06-6)	2.15	10.23
UG069	CORAL RED - (1000 - 1220°C - Cone 06-6)	2.15	10.23
UG071	ROCKET RED	2.15	10.23
UG073	RUBY RED - (1000 - 1220°C - Cone 06-6)	2.15	10.23
UG081	BURGUNDY - (1000 - 1220°C - Cone 06-6)	2.15	10.23
UG085	ROSE PINK - (1000 - 1220°C - Cone 06-6)	2.15	10.23
UG087	PETAL PINK - (1000 - 1220°C - Cone 06-6)	2.15	10.23
UG089	CARNATION PINK	2.15	10.23
UG101	JASPER	2.15	10.23
UG105	JADE GREEN	2.15	10.23
UG109	PEACOCK	2.15	10.23
UG113	PARIS GREEN	2.15	10.23
UG117	LIME - (1000 - 1250°C - Cone 06-8)	2.15	10.23
UG121	CHARTREUSE - (1000 - 1250°C - Cone 06-8)	2.15	10.23
UG129	APPLE GREEN	2.15	10.23
UG133	OLIVE GREEN - (1000 - 1250°C - Cone 06-8)	2.15	10.23
UG137	FOREST GREEN	2.15	10.23
UG141	LEAF GREEN	2.15	10.23
UG149	BABY BLUE	2.15	10.23
UG153	TURQUOISE	2.15	10.23
UG157	SUMMER BLUE	2.15	10.23
UG161	ELECTRIC BLUE	2.15	10.23
UG165	BRIGHT BLUE	2.15	10.23
UG173	ORCHID - (1000 - 1220°C - Cone 06-6)	2.15	10.23
UG177	LAVENDER - (1000 - 1220°C - Cone 06-6)	2.15	10.23
UG183	VIOLA	2.15	10.23
UG185	ROYAL PURPLE - (1000 - 1220°C - Cone 06-6)	2.15	10.23
UG189	PURPLE BLUE - (1000 - 1220°C - Cone 06-6)	2.15	10.23
UG193	ART GREY	2.15	10.23
UG197	GOLD BROWN - (1000 - 1220°C - Cone 06-6)	2.15	10.23
UG199	MID-BROWN	2.15	10.23
UG201	REDWOOD - (1000 - 1220°C - Cone 06-6)	2.15	10.23
UG204	TERRACOTTA - (1000 - 1100°C - Cone 06-03)	2.15	10.23
UG206	QIAOKELI	2.15	10.23
UG209	ANTIQUÉ BROWN - (1000 - 1220°C - Cone 06-6)	2.15	10.23
UG213	CRIMSON - (1000 - 1220°C - Cone 06-6)	2.15	10.23
UG216	COBALT BLACK	2.15	10.23

## Café Colours - Underglaze



Code	Café Colours - Underglaze	60ml	500ml
<i>Firing Range: 1000-1101°C (Cone 06-03)</i>			
CC001	SNOW WHITE	2.34	10.34
CC005	TUSK-TUSK	2.34	
CC009	KERNEL	2.34	
CC013	KINKY PINK	2.34	10.34
CC015	2 PINKY	2.34	10.34
CC017	NECTAR	2.34	10.34
CC021	OL CORAL	2.34	10.34
CC025	NU CORAL	2.34	10.34
CC029	ORANGE SUNSET	2.34	10.34
CC033	YELLOW TERRA	2.34	10.34
CC037	RED ROSIE	2.34	10.34
CC041	FLOWER POWER	2.34	
CC043	EYE IN ONE	2.34	10.34
CC045	TICKLED PINK	2.34	10.34
CC049	MELLOW YELLOW	2.34	10.34
CC053	YELLOW HAZE	2.34	10.34
CC057	HEY CORAL	2.34	10.34
CC061	ROSSO	2.34	10.34
CC065	SCARLET	2.34	10.34
CC069	ABLAZE	2.34	10.34
CC073	MOUSY BROWN	2.34	10.34
CC077	MOCHA	2.34	10.34
CC081	RED GUM	2.34	10.34
CC083	OLD OAK	2.34	10.34
CC085	WISTERIA MIST	2.34	10.34
CC089	WISLEY PINK	2.34	10.34
CC093	ELINOR LILAC	2.34	10.34
CC097	PURR PULL	2.34	
CC101	PURPLE HEART	2.34	
CC105	WINE MEISTER	2.34	10.34
CC109	WHINING	2.34	10.34
CC113	SILVER STREAK	2.34	10.34
CC115	HI HO	2.34	10.34
CC117	JADED	2.34	10.34
CC121	MINTY MINT	2.34	10.34
CC125	FIGARO	2.34	10.34
CC129	GEEPERS	2.34	10.34
CC133	TROPICAL WATERS	2.34	
CC137	SPARKLING EMERALD	2.34	10.34
CC141	SOFT PASTURES	2.34	10.34
CC143	OLIVER ERA	2.34	10.34
CC144	GREEN DREAM	2.34	10.34
CC145	FOREST 4 TREES	2.34	10.34
CC149	TALL TAILS	2.34	10.34
CC153	BIRDS LIFE	2.34	10.34
CC157	AQUA MARINA	2.34	10.34
CC161	BLUE BY YOU	2.34	10.34
CC165	FANCY PANCY	2.34	10.34
CC169	CELESTE	2.34	10.34
CC173	C'OTE AZURE	2.34	10.34
CC177	TUTTO BLU	2.34	10.34
CC181	TINSEL TEAL	2.34	
CC185	AZZURO	2.34	10.34
CC189	MIDNIGHT HOUR	2.34	10.34
CC193	RUSTY NAILS	2.34	10.34
CC197	TUTTO NERO	2.34	10.34

## PRICES

Please be aware that prices may change during the life of this price list. This is offered as a guide and we must emphasize that prices may change without notice. If the price of any goods you wish to buy is important we are pleased to supply you with a written quotation. Quotations secure the prices of goods for 30 days from the date they are issued.

# Onglaze Colours & Medias

## Sunshine Onglaze Colours



Code	Sunshine Onglaze	Firing Range °C	Cone	25g	100g	500g
3500	REED GREEN	730-860	017-012	3.88	8.38	34.98
3501	CHROME GREEN	730-860	017-012	3.41	6.50	26.51
3502	AZURE BLUE	730-860	017-012	3.62	7.34	30.31
3503	LEMON YELLOW	730-860	017-012	3.62	7.34	30.31
3504	LAMP BLACK	730-860	017-012	3.44	6.63	27.09
3505	SLATE GREY	730-860	017-012	3.50	6.86	27.09
3506	CHESTNUT BROWN	730-860	017-012	3.25	5.85	23.60
3507	OCHRE	730-860	017-012	3.36	6.30	25.63
3508	POLAR WHITE	730-860	017-012	3.70	7.63	31.61
3509	MANDARIN YELLOW	730-860	017-012	3.57	7.12	31.60
3510	BRIGHT ORANGE	730-860	017-012	3.64	7.41	30.63
3511	POPPY RED	730-860	017-012	3.25	11.36	48.41
3512	CARDINAL RED	730-860	017-012	4.92	12.53	53.67
3513	TURQUOISE	730-860	017-012	3.70	7.64	31.64
3514	FERN GREEN	730-860	017-012	3.52	6.93	28.44
3515	IRON RED	730-860	017-012	5.65	15.47	66.88
3516	COBALT BLUE	730-860	017-012		PO.A	
3517	MAGENTA	730-860	017-012		PO.A	
3518	PURPLE RED	730-860	017-012		PO.A	
3521	PURPLE	730-860	017-012		PO.A	
3522	SAFFRON	730-860	017-012	3.90	8.46	35.36
3520	ONGLAZE FLUX	730-860	017-012		PO.A	

## Medias

Code	Medias	100ml	125ml	250ml	500ml	2.5l
3974	UNDERGLAZE MEDIA		1.44	1.95	2.48	7.74
3975	UNI-MEDIA	3.69		6.98	11.67	
3976	TURPENTINE				POA	
3977	COVERCOAT*	POA			POA	
3978	COVERCOAT THINNERS*	POA			POA	
3979	SILK SCREEN MEDIUM*				POA	

Note: Products marked \* are to order only.



'Heart' & section of 'Coast Rectangle' - Wall panels in fused glass. By Ruth Lyne using Clayman Onglaze Colour Range  
www.ruthlyne.co.uk

# Precious Metal Lustres

## Precious Metal Lustres

Code	Precious Metal Lustres	Firing Range °C	5g	25g
3710	LEMON GOLD	See info	49.22	
3712	BRIGHT PLATINUM	See info	29.00	
3713	COPPER	See info	31.33	
3715	BRONZE	See info	33.15	

## Coloured Lustres

Code	Coloured Lustres	Firing Range °C	5g	25g
3650	BLUE	See info	6.12	
3651	RED	See info	16.40	
3652	BLACK	See info	20.52	
3654	GREEN	See info	4.35	
3655	AMBER	See info	1.24	
3657	YELLOW	See info	1.46	
3658	ORANGE	See info	1.25	
3659	VIOLET	See info	9.94	
3714	MOTHER OF PEARL - IRIS	See info	1.30	4.01

## Lustre Accessories

Code	Lustres Accessories	25g
3647	LUSTRE THINNERS	2.53



3710  
Lemon Gold



3712  
Bright Platinum

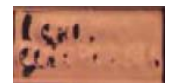

3713  
Copper



3715  
Bronze



3650  
Blue



3651  
Red



3652  
Black



3654  
Green



3655  
Amber

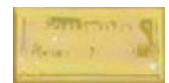

3657  
Yellow



3658  
Orange



3659  
Violet



3714  
Mother of Pearl - Iris

Note: Representation of lustres is only as good as the limitation of print.

# Raw Materials

## Raw Materials



Code	Raw Materials	100g	500g	2.5kg	5kg	10kg	12.5kg	25kg	50kg
5100	ALUMINA HYDRATE		2.63	11.41	17.45	29.54	33.19	60.13	96.20
5109	BARIUM CARBONATE		1.21	4.41	8.14	14.92	16.19	32.38	53.00
5111	ZIRCON BATT WASH		3.58	16.33	40.84	54.44	65.81	138.19	208.59
5115	BENTONITE		1.02	3.70	6.66	11.84	13.00	21.45	
5116	BONE ASH		1.80	8.22	15.18	27.83		58.75	105.75
5117	GERSTLEY BORATE		REPLACEMENT NOW AVAILABLE - 5122 GILLESPIE BORATE						
5119	COLEMANITE		1.64	7.58	12.12	21.21		45.38	82.50
5120	CORNISH STONE		SUBSTITUTE NOW AVAILABLE - 5121 CLAYMAN STONE						
5121	CLAYMAN STONE		1.53	5.48	8.17	13.95	16.77	30.84	52.88
5122	GILLESPIE BORATE		5.37	21.64	39.56	74.18	100.51	158.38	
5125	DOLOMITE - 150's			1.99	3.67	5.96	7.73	17.16	29.74
5130	POTASH FELDSPAR			2.99	5.24	8.38	10.20	16.93	32.12
5131	SODA FELDSPAR			3.17	5.78	9.87	12.30	18.65	33.90
5132	SPODUMENE		2.39	12.26	19.62	38.26		80.94	
5133	FLINT			3.50	5.59	9.23	11.27	18.45	35.79
5140	ILMENITE (FINE)	1.30	3.19	14.78					
5141	ILMENITE (COARSE)	1.44	2.54	10.84					
5150	LITHIUM CARBONATE	2.34	11.05	47.32	105.15	189.27			
5151	LEPIDOLITE			DISCONTINUED					
5154	MAGNESIUM CARBONATE (Light)		4.27	19.54	34.85	61.26			
5155	CRYOLITE		2.50	7.28	13.77	24.40			
5163	NEPHELINE SYENITE			4.75	7.60	10.64	14.40	27.16	48.89
5164	PETALITE		1.56	7.90	13.17	22.83		46.00	83.80
5165	QUARTZ			2.58	3.87	6.88	8.50	13.05	23.20
5170	WHITE SAND								
5171	BUFF SAND		1.14	2.49	4.32	7.14	8.94	16.50	30.25
5172	TALC			4.85	8.62	14.22	16.67	30.69	57.76
5175	WOLLASTONITE		1.50	6.40	11.42	20.07	24.60	42.93	
5176	WHITING			1.69	2.43	4.24	4.99	9.34	17.68

# Powdered Clays

## Powdered Clays

Code	Powdered Clays	2.5kg	5kg	10kg	25kg	50kg	250kg
5118	CHINA CLAY	1.93	3.66	6.56	12.26	23.90	107.30
5401	BALL CLAY - HYPLAS 71	2.57	3.24	5.80	11.50	22.42	100.60
5402	BALL CLAY - HV	2.25	2.84	5.08	9.00	17.56	78.80
5403	BALL CLAY - HYMOD AT	2.39	3.04	5.44	10.36	20.20	90.70
5406	RED TERRA-COTTA	CURRENTLY UNAVAILABLE					
5408	CHINA CLAY - GROLLEG	4.08	5.16	9.24	21.60	42.12	189.00
5409	FIRECLAY	CURRENTLY UNAVAILABLE					
5410	CHINA CLAY - STANDARD PORCELAIN						
5414	HF (CRAFT) PORCELAIN						

# Opacifiers

## Opacifiers

Code	Opacifiers	100g	500g	2.5kg	5kg	10kg	
5578	TITANIUM DIOXIDE		1.67	4.03	18.53	34.42	63.56
5579	TIN OXIDE		6.45	27.84	125.66	234.56	452.36
5581	ZINC OXIDE		1.60	3.09	14.25	26.88	48.88
5582	ZIRCONIUM SILICATE		1.58	6.23	29.09	55.26	106.64

Note: All opacifiers are packed in re-usable plastic containers. The 500g and 2.5kg tubs come complete with carrying handles.

# Grogs

## Grogs

Code	Grogs	2.5kg	5kg	10kg	12.5kg	25kg	50kg	250kg
5304	FIREBRICK GROG - 85's to DUST	4.26	7.33	13.07	13.50	25.58	46.04	213.13
5308	MOLOCHITE -30's	4.25	7.86	14.00	14.58	27.74	49.92	231.13
5309	MOLOCHITE 50-80's	4.94	9.14	16.28	17.16	32.90	59.22	274.10
5310	MOLOCHITE -120's	4.38	8.12	14.48	15.09	28.76	51.76	239.60
5311	MOLOCHITE -200's	4.42	8.16	14.56	15.21	29.00	52.20	241.60
5312	MOLOCHITE -80's	4.25	7.86	14.00	14.58	27.74	49.92	231.10
5315	CORDIERITE +50's	5.50	10.18	18.16	19.29	37.15	66.88	309.60
5316	CHAMOTTE -1.00 +0.5mm	3.92	7.26	12.96	13.37	20.26	36.48	168.90
5317	HIGH PURE - 5's DUST	9.12	12.26	19.80		38.48	67.64	
5318	HIGH PURE - 18-36's	8.00	10.74	17.36		33.19	58.32	
5319	HIGH PURE - 30-80's	8.00	10.74	17.36		33.19	58.32	

# Frits

## Frits

Code	Frits	Firing Range °C	Cone	500g	2.5kg	5kg	10kg	12.5kg	25kg
5681	LEAD BISILICATE	860-1100	012-03	4.29	20.69	39.14	73.84	82.54	152.74
5682	LEAD SESQUISILICATE	860-1080	012-04	3.87	18.46	34.92	65.84	73.49	135.84
5683	BORAX FRIT	960-1140	08-1	2.07	8.94	16.92	31.88	38.38	63.81
5684	CALCIUM BORATE FRIT	1030-1180	05-4	5.39	23.64	43.00	83.12	99.05	191.02
5685	HIGH ALKALINE FRIT	860-1060	012-04	3.08	14.32	27.10	51.08	56.72	104.55
5683	LOW EXPANSION FRIT	1020-1150	05-1	2.00	8.57	16.22	30.60		61.04
5687	BOROSILICATE FRIT - FERRO 3110	1000-1060	06-04	4.71	22.90	43.32	81.68		166.42
5689	BOROSILICATE FRIT - FERRO 3712	1040-1100	05-03	2.45	10.96	20.74	39.12		79.11

# Oxides

## Oxides

Code	Oxides	25g	100g	500g	2.5kg	5kg	10kg
5561	CHROME OXIDE			1.82	6.97	29.98	
5562	COBALT OXIDE			3.98	8.14	38.18	146.36
5563	COBALT CARBONATE			3.48	7.01	34.22	142.28
5564	COPPER OXIDE			1.84	6.68	32.19	
5565	COPPER CARBONATE			1.57	5.70	24.58	
5567	BLACK IRON OXIDE			0.98	2.40	10.80	20.36 37.04
5569	RED IRON OXIDE			0.79	1.08	4.52	8.04 15.64
5568	IRON SPANGLES			1.01	2.53	11.45	
5570	SYNTHETIC IRON OXIDE			0.95	1.89	9.10	16.18
5571	YELLOW IRON OXIDE			1.21	2.33	7.82	15.20 29.82
5573	MANGANESE DIOXIDE			0.82	1.34	5.21	9.88 18.08
5574	MANGANESE CARBONATE			0.97	2.24	11.39	20.88 37.96
5575	NICKEL OXIDE			4.21	18.53	91.47	
5576	RUTILE - LIGHT			1.64	4.80	23.43	42.60 76.68
5580	VANADIUM PENTOXIDE			7.60	37.54	178.36	

Note: All oxides are packed in re-usable plastic containers. The 500g and 2.5kg tubs come complete with carrying handles.

# Miscellaneous

## Miscellaneous Liquids

Code	Miscellaneous Liquids	60ml	125ml	250ml	500ml	2.5 litres
5200	CALCIUM CHLORIDE				1.93	7.69
5214	SODIUM SILICATE - 100°TW				3.10	9.11
5216	SODIUM SILICATE - 140°TW				3.10	8.80
5217	SODIUM SILICATE - 75°TW				4.31	14.46
SP013	COLOR MASK	2.00			8.68	
5221	LATEX RESIST	DISCONTINUED UNTIL FURTHER NOTICE				
5222	WAX RESIST		1.25	1.70	2.77	9.59
5223	SODIUM DISPEX			3.22	5.02	18.49
5224	GLAZE SUSPENDA			2.89		

## Miscellaneous Materials

Code	Miscellaneous Materials	100g	500g	2.5kg
5210	GUM ARABIC	2.94	8.90	42.37
5215	SODA ASH		0.95	4.21
5212	CERAGUM	2.20	8.85	41.45

## Sundry Items

Code	Sundry Items	100g	500g	2.5kg	59ml	140ml	500ml	2.5 litres	5 litres	5 x 5 litres
5225	MOULDMAKER'S SIZE		4.41	15.57						
5227	AC MENDER				3.59					
SP009	CLAY MENDER					3.65				
5230	CERAGEL						2.74	8.82	16.25	71.22
5128	ATAXIDE	3.68								

YOUR ORDER FOR  
KILNS OR  
EQUIPMENT  
MEANS A LOT TO  
US!



When you buy a kiln or equipment (to a greater value than £200) from us we would like to say a big thank you, and also say our service does not stop there. We offer a large range of clays, slips, materials, glazes and colours, as well as tools that have been selected to help the hobbyist and professional, alike. So we will give you a voucher as part of our thank you. It can be applied to your next order of anything from our range, except kilns and equipment.

## 6999 - CLAY TRAP

The Clay Trap measures 552 x 400 x 270mm deep. The cut-away lid reveals the two weirs, the inlet on the right and the outlet, which has a 76mm water seal on the left. Both inlet and outlet have coupling nuts for joining 38mm Vulcathene Mechanical pipe. Also purchase two 6999/1 Adaptor Kits for connection to a standard 38mm waste pipe.

An essential for any workshop

**£347.24 + VAT**

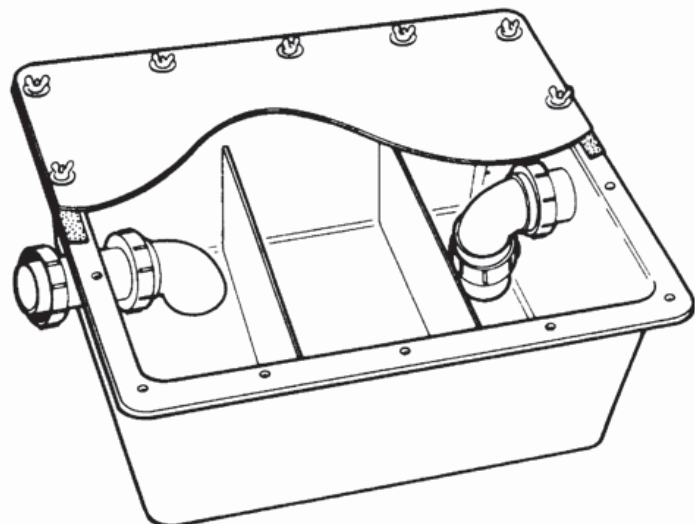



## Turning Tools

Code	Turning Tools	Each
6100	PEAR TOOL	3.34
6101	TRIANGULAR TOOL	3.34
6102	QUADRILATERAL TOOL	3.34
6103/410	PEAR TOOL	4.20
6103/411	TRIANGULAR TOOL	4.20
6103/412	QUADRILATERAL TOOL	4.20
6105/415	LEAF TURNING TOOL	4.20
6105/416	DIAMOND TURNING TOOL	4.20
6110	S/S DIAMOND	3.85
6111	S/S LEAF	3.85
6112	S/S ROUND	3.85
6113	S/S SQUARE	3.85
6114	DOUBLE ENDED	6.05
6115	STEEL - SQUARE	2.36
6116	STEEL - ROUND	2.36
6117	STEEL - LEAF	2.36
6118	STEEL - DIAMOND	2.36

## Turning/Modelling Tools

Code	Turning/Modelling Tools	Each
6120	GROUND EDGE - 8"	3.06
6121	GROUND EDGE - 8"	3.06
6122	GROUND EDGE - 8"	3.06
6123	GROUND EDGE - 8"	3.06
6124	GROUND EDGE - 8"	2.45
6125	RIBBON TURNING TOOL	2.73
6126	RIBBON TURNING TOOL	2.73
6129	RIBBON TURNING TOOL	2.87
6130	GROUND EDGE - 6"	2.21
6131	GROUND EDGE - 6"	2.21
6132	GROUND EDGE - 6"	2.21
6133	GROUND EDGE - 6"	2.21
6134	GROUND EDGE - 6"	2.21
6137/2	GROUND EDGE TOOL SET	14.60

## Wire Modelling Tools

Code	Wire Modelling Tools	Each
6140	6"	3.40
6141	6"	3.40
6142	6"	3.40
6143	8"	3.35
6144	8"	3.35
6145	11"	4.15
6146	11"	4.15

## Super Hardwood Modelling Tools

Code	Super Hardwood Modelling Tools	Each
6150	MODELLING TOOL	2.25
6151	MODELLING TOOL	2.25
6152	MODELLING TOOL	2.25
6153	MODELLING TOOL	2.25
6154	MODELLING TOOL	2.25
6155	MODELLING TOOL	2.25

## Additional Modelling Tools

Code	Additional Modelling Tools	Each
6219	NYLON TOOL SET	2.85
6231	PLASTIC MODELLING TOOL SET	1.05

## Stainless Steel Modelling Tools

Code	Stainless Steel Modelling Tools	Each
6170/20	S/S TOOL	1.89
6170/21	S/S TOOL	1.89
6170/23	S/S TOOL	1.85
6170/24	S/S TOOL	1.35
6170/25	S/S TOOL	1.35
6170/26	S/S TOOL	1.35
6170/28	S/S TOOL	1.35
6170/401	S/S TOOL	3.85
6170/404	S/S TOOL	2.36
6170/405	S/S TOOL	3.10

## Dental Tools

Code	Dental Tools	Each
6172/50	DENTAL TOOL	1.45
6172/51	DENTAL TOOL	1.70
6172/53	DENTAL TOOL	1.70
6172/55	DENTAL TOOL	1.75
6172/58	DENTAL TOOL	1.70

## Rifflers

Code	Rifflers	Each
6175/203	RIFFLER	5.70
6175/207	RIFFLER	6.10

## Hardwood Modelling Tools

Code	Hardwood Modelling Tools	Each
6180	6"	1.14
6181	6"	1.14
6182	6"	1.14
6183	6"	1.14
6184	6"	1.14
6185	6"	1.14
6186	6"	1.14
6187	6"	1.14
6188	6"	1.14
6189	6"	1.14
6190	6"	1.14
6191	6"	1.14
6192	6"	1.14
6193	6"	1.14
6194	6"	1.14
6195	6"	1.14

## Sculpture Tools

Code	Sculpture Tools	Each
6260	TOOL - 12"	3.75
6261	TOOL - 12"	3.75
6262	TOOL - 12"	3.75
6270	TOOL	5.63
6271	TOOL	5.63
6272	TOOL	5.63
6273	TOOL	5.63
6274	TOOL	5.63
6275	SCULPTURE'S THUMB	1.75

## Forged Steel Tools

Code	Forged Steel Tools	Each
6240	FORGED STEEL TOOL	8.57
6241	FORGED STEEL TOOL	6.71
6242	FORGED STEEL TOOL	6.73
6243	FORGED STEEL TOOL	8.16
6244	FORGED STEEL TOOL	8.41
6245	FORGED STEEL TOOL	6.68
6246	FORGED STEEL TOOL	9.96
6247	FORGED STEEL TOOL	9.84
6248	FORGED STEEL TOOL	7.42
6249	FORGED STEEL TOOL	7.86
6252	FORGED STEEL TOOL	9.17
6253	FORGED STEEL TOOL	8.43
6254	FORGED STEEL TOOL	8.58
6255	FORGED STEEL TOOL	6.58
6256	FORGED STEEL TOOL	8.18
6257	FORGED STEEL TOOL	6.53
6258	FORGED STEEL TOOL	7.52
6259	FORGED STEEL TOOL	6.94
6263	FORGED STEEL TOOL	7.46
6264	FORGED STEEL TOOL	9.71
6265	FORGED STEEL TOOL	7.38
6266	FORGED STEEL TOOL	7.14
6267	FORGED STEEL TOOL	8.53

## Griffon Tools

Code	Griffon Tools	Each
6275/150	GRIFFON TOOL	3.25
6275/152	GRIFFON TOOL	5.75

## Hand Extruders

Code	Hand Extruders	Each
6339	CLAY GUN	6.96

## Plaster Tools

Code	Plaster Tools	Each
6350/303	PLASTER SPATULA	2.75
6350/406	PLASTER SPATULA	3.25
6350/407	PLASTER SPATULA	2.75
6350/408	PLASTER SPATULA	2.50

## Needles

Code	Needles	Each
6370	THIN	1.63
6371	THICK	1.63
6372	ALL METAL	1.18

## Clean-up Tools

Code	Clean-up Tools	Each
6380/452	CLEAN-UP TOOL	3.25
6380/454	CLEAN-UP TOOL	3.25
6380/455	CLEAN-UP TOOL	3.25
6380/456	CLEAN-UP TOOL	3.25
6380/457	CLEAN-UP TOOL	3.25

## Coilers

Code	Coilers	Each
6340	0.5" (1/4")	6.00
6341	0.625" (5/8")	6.00
6342	0.75" (3/4")	6.00

## Scraffito Tools

Code	Scraffito Tools	Each
6353	SCRAFFITO TOOL	2.10
6354	SCRAFFITO TOOL	2.10
6355	SCRAFFITO TOOL	2.10
6356	STYLUS TOOL	1.82
6357	LOOPED SCRAFFITO TOOL	2.10

## Strip Tools

Code	Strip Tools	Each
6381	SQUARE	5.25
6382	ROUND	5.25

## Clay Cutters

Code	Clay Cutters	Each
6330	17" NYLON	1.47
6331	14" TWISTED	1.84
6332	18" WEDGING	1.84
6333	12" THIN	1.65
6334	20" MEDIUM	1.65
6335	SET - contains 2 x 6333, 1 x 6332	4.35

## Rubber Kidneys

Code	Rubber Kidneys	Each
6460	SMALL/SOFT	1.73
6461	MEDIUM/SOFT	2.04
6462/1	RUBBER KIDNEY - Hard	2.10
6462/2	RUBBER KIDNEY - Soft	1.40
6462/3	RUBBER KIDNEY - Small Soft	1.86
6463/1	RUBBER KIDNEY - Small Firm	2.00
6464/1	RUBBER KIDNEY SET	6.79

## Rolling Tools

Code	Rolling Tools	Each
6399	ROLLING PIN - 17.5"	4.38
6397	ROLLING CLOTH - 36 x 24"	5.35
6398/12	ROLLING GUIDES - 12mm	2.45
6398/9	ROLLING GUIDES - 9mm	2.25
6398/7	ROLLING GUIDES - 7mm	2.05
6399/1	TEXTURED ROLLING PIN	3.96
6399/2	TEXTURED ROLLING PIN	3.96
6399/3	TEXTURED ROLLING PIN	3.96
6399/4	ROLLING PIN - 8.5"	1.35

## Calipers

Code	Calipers	Each
6390	PERSPEX - 8"	6.68
6391	PERSPEX - 12"	8.33
6392	STAINLESS STEEL - 8"	7.60
6394	LIP METER	7.77

## Tile Cutters

Code	Tile Cutters	Each
6550	4.25" SQUARE	28.03
6551	6" SQUARE	28.03
6552	HEXAGONAL	DISC.
6557	MINI CUTTER SET	3.17
6558	PATTERN CUTTER SET	4.35
6559	PATTERN CUTTER SET	4.35
6560/1	PLASTIC CUTTERS FOR KIDS	0.95
6560/2	PLASTIC CUTTERS FOR KIDS	0.95
6560/3	PLASTIC CUTTERS FOR KIDS	0.95
6560/4	PLASTIC CUTTERS FOR KIDS	0.95

## Sundry Tools

Code	Sundry Tools	Each
6300	POTTERS KNIFE	2.56
6318	TAPERED KNIFE	3.10
6317	MOLD TRIMMING TOOL	0.99
6319	PALETTE KNIFE	1.80
6395	BOW TRIMMER	8.78
6396	BOW HARP	19.25
6396/1	SPARE WIRE - for 6396	1.95

## Metal Kidneys

Code	Metal Kidneys	Each
6446	BLUE STEEL - Small	0.46
6447	BLUE STEEL - Medium	0.49
6448	BLUE STEEL - Rectangular	0.41
6449	BLUE STEEL - Serrated	0.53
6450	BLUE STEEL - Flexible	0.46
6451	STAINLESS STEEL	0.68
6452	STAINLESS STEEL	0.75
6453	STAINLESS STEEL - Serrated	1.00
6454	STAINLESS STEEL - Rectangular	0.80
6455	STAINLESS STEEL - Peardrop	0.83
6456	S/S - Serrated Rectangular	0.90

## Miscellaneous

Code	Miscellaneous	Each
6386	MORTAR & PESTLE	17.37
6393	GLAZING TONGS	8.61
6393/1	GLAZING CLAW with CLIP	6.02
6393/2	DIPPING TONGS	11.45

## Stamps

Code	Stamps	Each
6470	POLY STAMPS	3.70
6471	WOOD STAMPS	3.69

## Hole Cutters

Code	Hole Cutters	Each
6310/1	SALT	4.50
6310/2	PEPPER	4.50
6352/1	TAPERED	3.48
6352/2	5mm	2.44
6352/3	8mm	2.80
6352/4	13mm	2.95
6352/5	21mm	3.48

## Tool Sets

Code	Tool Sets	Each
6137/1	CERAMIC TOOL SET	8.15
6137/2	GROUND EDGE TOOL SET	13.01
6137/3	POTTERY TOOL KIT (12 Tools)	13.56
6137/4	ECONOMY TOOL SET	3.05
6137/5	POTTERY TOOL KIT (10 Tools)	15.45
6138	POTTERY TOOL KIT	10.60
6139	BIG WOODEN FORMING SET	12.09
6250	MODELLING/SCULPTURE	10.60
6308	GROUND EDGE/SCULPTURE	10.80
6174/1	WOODEN MODELLING TOOLS	5.24
6174/2	WOODEN MODELLING TOOLS	8.61
6174/3	SUPER MODELLING TOOLS	12.13
6174/4	SUPER MODELLING TOOLS	16.56
6215	WOODEN MODELLING TOOLS	12.49
6216	WOODEN MODELLING TOOLS	8.70
6217	WOODEN MODELLING TOOLS	10.40
6219	NYLON MODELLING TOOLS	2.85
6231	PLASTIC MOD. TOOL SET	1.05
6335	CLAY CUTTERS	4.35
6464/1	RUBBER KIDNEY SET	6.79

## Bamboo Tools

Code	Bamboo Tools	Each
6320	COMB	3.75
6321	FLUTER	2.95
6322	SPEAR	3.75
6323	RIB - LARGE	2.95
6324	RIB - SMALL	2.00
6325	KNIFE	3.75

## Throwing Ribs

Code	Throwing Ribs	Each
6360	STRAIGHT WITH CURVE	2.36
6361	CONVEX OVAL	2.36
6362	FLAT WITH CONCAVE	3.15
6363	THROWING STOCK	3.15
6364	FLAT WITH TOOTH EDGE	3.05
6365	METAL THROWING PROFILE	1.65
6369	BEECHWOOD	3.05

## Scrapers

Code	Scrapers	Each
6385	BENCH SCRAPER - 160mm	3.95

## 13amp HAWK T/L KILN



Prices on page 26

## Sponges

Code	Sponges	Each
6400	BENCH	1.10
6401	TAPERED	0.75
6403	BARREL	1.15
6404	LOLLIPOP	1.19
6405	ROUND SYNTHETIC	1.10
6406	BULLNOSE DOTTLE - Large	1.40
6406/1	BULLNOSE DOTTLE - Small	1.24
6406/2	TAPERED DOTTLE	1.09
6407/1	SMALL PAINTBRUSH SPONGE	0.75
6407	LARGE PAINTBRUSH SPONGE	1.28
6409	NATURAL - Medium	3.54
6410	NATURAL - Elephant Ear	8.55

## Slip Trailers

Code	Slip Trailers	Each
6375/1	SLIP TRAILER - Small	2.43
6375/2	SLIP TRAILER	4.16
6375/3	PRECISION SLIP TRAILER SET	19.61
6376	SLIP TRAILER - ECONOMY	1.05
6377	SLIP TRAILER KIT	5.76

## Tool Sets



6137/1 - Ceramic Tool Set



6250 - Modelling / Sculpture Set



6215 - Wooden Modelling Tools



6137/2 - Ground Edge Tool Set



6174/1 - Wooden Modelling Tools



6216 - Wooden Modelling Tools



6138 - Pottery Tool Kit



6174/4 - Super Modelling Tools



6219 - Nylon Modelling Tools

PRICES  
FIELD

# Workshop Tools

## Wooden Rim Sieves

Code	Wooden Rim Sieves	Each
6512	60's - 6" dia.	10.10
6513	80's - 6" dia.	11.72
6514	120's - 6" dia.	12.22
6522	60's - 8" dia.	12.92
6523	80's - 8" dia.	13.56
6524	120's - 8" dia.	13.56
6532	60's - 10" dia.	14.20
6533	80's - 10" dia.	14.20
6534	120's - 10" dia.	15.20

## Plastic Rim Sieves

Code	Plastic Rim Sieves	Each
6566/120	120's - 165 x 120mm	14.19
6566/80	80's - 165 x 120mm	13.74
6566/60	60's - 165 x 120mm	13.53

## Test Sieves

Code	Test Sieves	Each
6544/120	120's -	7.78
6544/80	80's -	7.78
6544/60	60's -	7.78

## Cup Lawns

Code	Cup Lawns	Each
6540	60's - 4" dia.	6.39
6541	80's - 4" dia.	6.56
6542	120's - 4" dia.	6.91
6543	200's - 4" dia.	7.44

## Miscellaneous

Code	Workshop Aids	Each
4901	PLASTER SINK	32.10
7333	BIN DOLLEY - Adjustable	35.18
6998	GLECO TRAP - 1.8 litre	163.65
6999	CLAY TRAP - 20 litre	347.24
6999/1	CLAY TRAP ADAPTOR KIT x 2	5.00

## Metal Rim Sieves

Code	Metal Rim Sieves	Each
6570/120	120's - 165 x 120mm	11.25
6570/80	80's - 165 x 120mm	11.25
6570/60	60's - 165 x 120mm	11.25

## Protective Clothing

Code	Protective Clothing	Each
6420	COTTON DRILL APRON	4.63
6420/1	DRILL APRON - Blue/White	9.00
6420/2	NATURAL PVC	3.75
6423	DUST MASK RESPIRATOR	11.23
6423/1	P3 FILTER - Toxic Dusts & Fumes	6.10
6423/2	PRE-FILTER for 6423 x 25	5.33
6423/3	P2 FILTER - Org. Vapours & Dust	5.00
6423/4	P2 FILTER - Toxic Dusts & Fumes	2.70
6424/1	P2 DISPOSABLE DUST MASK	1.12
6424/1-20	6424/1 x 20	18.68
6424/2	P2 DISP. DUST MASK - VALVED	1.50
6424/2-15	6424/2 x 15	18.69
6425/1	P3 DISP. DUST MASK - VALVED	3.33
6425/2	P3 DISP. DUST MASK - VALVED	5.48
6425/3	P2 DISP. DUST MASK - S/M	1.74
6425/4	P2 DISP. DUST MASK - M/L	1.74

## Plastic Ware

Code	Plastic Ware	Each	x 10
6920	50ml JAR	0.39	3.50
6921	130ml JAR	0.54	5.00
6923	150ml JAR	0.58	5.30
6922	500ml JAR	0.81	7.40
6927/75	75ml BOTTLE	0.53	4.80
6927/125	125ml BOTTLE	0.68	6.20
6927/250	250ml BOTTLE	0.72	6.60
6927/500	500ml BOTTLE	0.95	8.60
6936	500ml TUB	0.33	2.90
6938	850ml TUB + HANDLE	0.42	3.60
6937	1000ml TUB + HANDLE	0.39	3.30
6901	2.5 litre TUB + HANDLE	1.25	10.20
6902	5 litre TUB + HANDLE	0.98	8.10
6903	10 litre TUB + HANDLE	2.22	18.20
6904	25 litre TUB + HANDLE	6.12	50.20
6906	90 litre CLAY BIN	19.99	
6908	2.5 litre JERRYCAN	1.18	10.10
6907	5 litre JERRYCAN	1.19	10.20
6915	BOWL - 8"	1.58	
6916	FUNNEL	2.25	
6918	0.9 litre JUG	1.15	10.00
6940/1	SCOOP - Large	5.50	
6940/2	SCOOP - Small	2.75	
6940/3	SCOOP - Mini	2.10	

## Scales

Code	Scales	Each
6595/1	OHAUS CL5000 - 5kg/1g	53.38
6595/2	OHAUS CL501 - 500g/0.1g	62.53
6595/3	OHAUS CS5000 + PRO	74.94
6594	TRIPLE BEAM	215.40
6594/1	WEIGHT SET - for 6594	40.70

# Wheels & Equipment

## Electronic Wheels

Code	Electronic Wheels	Each
7112	SHIMPO RK35 WHEEL	499.00
7120	STAFFORDSHIRE THROWING	1530.00
7121	LINCOLN ELECTRONIC	1395.00
7122	SHIMPO RK3E WHISPER	994.00
7125	KNIGHTSBRIDGE	920.00
7128	CRAFTSMAN	1841.00
7129	FITZWILLIAM	1931.00
7135	BAILEY - LOW FORMAT	825.00
7137	SHIMPO RK3D WHISPER	839.06
7143	SHIMPO RK3E WHISPER T	599.00

## Wheel Accessories

Code	Wheel Accessories	Each
7140	10" ALLOY WHEELHEAD	160.00
7141	12" ALLOY WHEELHEAD	162.00
7147	WHEELHEAD STUDDING	45.00
7149	8" PLYWOOD WHEELBATT	4.16
7153	9" PLYWOOD WHEELBATT	4.16
7150	10" PLYWOOD WHEELBATT	4.59
7154	11" PLYWOOD WHEELBATT	4.73
7151	12" PLYWOOD WHEELBATT	5.67
7156	13" PLYWOOD WHEELBATT	6.18
7152	15" PLYWOOD WHEELBATT	6.91
7163	THROWING GAUGE - Wooden	DISC.
7168	EASI-LIFT WHEELHEAD	179.00
7168/1	PLYWOOD BATT	11.50
7185	MEDEX UNIVERSAL BATT	39.13

To purchase a studded wheelhead to use batts select the size of wheelhead required (10" or 12") and add the wheelhead studding option (7147). Unless otherwise specified the wheelhead is then supplied with two off-centre studs.

## Wheel Additions

Code	Wheel Additions	Each
7135/1	BAILEY WHEEL - TOOL SHELF	72.50
7135/2	BAILEY SHELF - SEAT	110.00
7135/3	BAILEY SHELF - REVERSE SWITCH	35.00
7156	SHIMPO - EXTENSION LEGS	55.05
7172	SEAT FOR KNIGHTSBRIDGE WHEELS	110.00
7180	FITZWILLIAM SPLASH TRAY	125.00
7181	CRAFTSMAN SPLASH TRAY	135.00
7182	FOOTREST - FITZWILLIAM & CRAFTSMAN	POA
7183	HAND CONTROL LEVER - FITZWILLIAM & CRAFTSMAN	POA

## Slab Rollers

Code	Slab Rollers	Each
7210	CLAY ROLLER - 3'	845.00
7211	CLAY ROLLER - 4'	865.00
7214	MOTORIZED CLAY ROLLER	2280.00
7215	NORTHSTAR PORTA-ROLLER	445.15

## Pugmills

Code	Pugmills	Each
7600	2" MINI + SAFETY GRID	1130.00
7601	3" MINI + SAFETY GRID	1525.00
7602	GUARD SWITCH UPGRADE FOR 7600 & 7601	280.00
7615	STAND for 7600/7601	206.00
7620	3" VERTICAL	2400.00
7625	4" VERTICAL DE-AIRING	3500.00

## Pugmill Add-ons

Code	Pugmill Add-ons	Each
7650/1	DIE PLATE - 6mm HOLE - for 7600/7610	56.00
7650/2	DIE PLATE - 10mm HOLE - for 7600/7610	56.00
7650/3	DIE PLATE - 13mm HOLE - for 7600/7610	56.00
7651/1	DIE PLATE - 6mm HOLE - for 7601/7611	95.00
7651/2	DIE PLATE - 10mm HOLE - for 7601/7611	95.00
7651/3	DIE PLATE - 13mm HOLE - for 7601/7611	95.00

## Spray Booths

Code	Spray Booths	Each
7800	WATERFALL	2695.00
7801	DRYBACK SPRAYBOOTH & STAND	910.00
7801/1	FLEXIBLE DUCTING - 1m	POA
7805	WATERFALL - 1m sq.	4365.00
7807	OPTIONAL LIGHT - for 7800/7805	140.00

## Spray Equipment

Code	Spray Equipment	Each
6601	472 PRO SPRAY GUN	54.55
6602	472 PRO SPRAY GUN + 777 COMPRESSOR KIT	191.75
6604	AIR HOSE - for 6601/6607	7.45
6606	ATOMIZER	1.85
6607	ASTURO SPRAY GUN	DISC.
6607/1	250cc NYLON CUP for Asturo	17.25
6608	PAINTEC SPRAY GUN	38.84
6608/1	0.8mm NOZZLE	1.37
6608/2	1.0mm NOZZLE	1.37
6608/3	1.2mm NOZZLE	1.37
6608/4	SMALL CONTAINER (Pack of 3)	3.13
6608/5	COMPRESSOR CONNECTING KIT	9.36
6608/6	NOZZLE SET - 0.8mm, 1.00mm & 1.2mm	3.90
6608/7	1 litre SPARE JARS + CAP	3.74
6608/8	AIR RELEASE VALVE	1.87
6608/9	FILTER	0.62
6608/10	SILICON LUBRICANT	0.65
6608/11	SMALL CONTAINER - Set of 3	1.86
6800	BASIC SPRAY GUN	16.99
6801	MINI SPRAY GUN	37.98
6801.001	SPARE BOTTLE - MINI SPRAY GUN	2.95
6802/1	PAASCHE H SPRAY GUN SET - Blister Pack	39.99
6803	TYRE ADAPTOR	5.17
6804	QUARTER INCH ADAPTOR	4.54
6808	AIR PROPELLANT - 750g	7.95

## Mixers

Code	Mixers	Each
7001	RAPID MIXER + BUCKET	340.00
7007	VIBRATORY SCREEN	345.00

We are pleased to quote for the delivery of any wheels or associated equipment. These deliveries are by pallet delivery service. As with all deliveries of this type, delivery will be to the nearest practicable point to the customer's premises. The carrier will off-load the pallet but removing the equipment from the pallet and moving into position is the responsibility of the customer.

## Whirlers

Code	Whirlers	Each
6700	STEEL - 8 x 4"	36.48
6701	ALLOY - 8 x 6"	28.36
6704	ALLOY - 8 x 3"	26.41
6709	MODELLING STAND	166.05
6711	CAST IRON WHIRLER - 20cm x 7cm	23.55
6712	CAST IRON WHIRLER - 25cm x 7.5cm	28.00
6714	STEEL - 10 x 4"	52.88
6715	STEEL - 12 x 6"	76.20

## Extruders

Code	Extruders	Each
7500	CLAYPRESS	167.00
7501	HOLLOW DIE SET - for 7500	68.00
7502	BLANK DIE - for 7500	5.00
7503	COIL DIE SET - for 7500	28.00
7505/5	BLANK DIE PLATES	19.65
7510	NORTH STAR CLAY EXTRUDER PACKAGE	323.74
7514	BIG BLUE EXTRUDER	987.25
7515/1	STANDARD ACCESSORY DIE KIT inc. Z BRACE	77.55
7515/2	BIG BLUE ADAPTOR FOR STD 4" DIES	33.57
7515/3	BIG BLUE DIE BRACE	35.53
7515/4	LARGE DIE SET FOR BIG BLUE	93.44
7515/5	MEDIUM DIE SET FOR BIG BLUE	93.44
7515/6	6" BLANK DIES FOR BIG BLUE	53.15
7515/7	6" SOLID DIE SET FOR BIG BLUE	82.25
7515/8	EXPANSION BOX	195.79

## Plaster Working Equipment

Code	Plaster Working Equipment	Each
7714	REVERSIBLE TURNING LATHE	1500.00
7720	VACUUM PLASTER MACHINE	3950.00
7721	PLASTER BENDER	2500.00
7722	MODELLING BENCH	1400.00

Code	Plaster Working Equipment Accessories	Each
7714/1	150mm (6") SPINDLE	130.00
7714/2	229mm (9") SPINDLE	150.00
7714/3	305mm (12") SPINDLE	190.00
7714/4	381mm (15") SPINDLE	215.00
7714/5	150mm (6") FACE PLATE	135.00
7714/6	203mm (8") FACE PLATE	155.00
7714/7	254mm (10") FACE PLATE	175.00
7714/8	150mm (5.9") CUP HEAD - 35mm deep	POA
7714/9	200mm (7.67") CUP HEAD - 35mm deep	POA

## Slip Equipment

Code	Slip Equipment	Each
7300	15 gallon BLUNGER	1585.00
7301	STAND - FOR 7300	220.00
7304	25 gallon BLUNGER	1780.00
7305	STAND - FOR 7304	220.00
7310	SLIP CASTING CENTRE	1080.00
7311	SLIP PUMP	780.00
7314	SLIP PREPARATION CENTRE	5000.00
7302	CASTING BENCH	195.00

# 7125 - KNIGHTSBRIDGE THROWING WHEEL



The Knightsbridge Wheel has been designed and developed using extensive experience and research into electronic control systems. It uses a 0.37Kw (1/2hp) motor which is controlled by the same control unit used in our more expensive wheels. This provides unrivalled power and torque in a wheel of this size and offers an extremely quiet and smooth operation.

The wheel is completed by its remote foot pedal which is fitted as standard as well the wheels ability to reverse rotation at the flick of a switch.

Seat shown is an optional extra.

## Quality engineering for just £920.00 + VAT

## Miscellaneous

Code	Miscellaneous	Each
7700	METAL DAMP CABINET	700.00
7701	METAL DAMP CABINET	495.00
7702	METAL DAMP CABINET	825.00
7703	METAL DAMP CABINET	795.00
7710	WARE TRUCK	295.00
7710/1	WARE BOARDS	19.00
7117	DRYING CABINET + HEATER	1955.00
7118	DRYING CABINET + HEATER	1310.00
7164	SLABBING BENCH - 1200 x 860 x 760mm	355.00
7166	WEDGING BENCH	510.00
7171	JIGGER & JOLLY - ELECTRONIC	2395.00
7173	VERTICAL JIGGER & JOLLY - ELECTRONIC	POA
7176	FILTER PRESS	POA
7177	GLAZE DIPPING UNIT	POA

# Kilns & Accessories

## 13amp Plug & Fire Top-Loading Kilns

Code	13amp T/L Kiln	kW	Kiln Only	+ST312P	+ST314P	+ST315P	ST316P	Furniture Set	Spare Kiln Batt	Element Set	Delivery
8155.0040	eco40 - 1.42 cu.ft	3.0	1104.70	1275.00	1304.25	1326.25	1326.25	61.66	POA	POA	POA
8150.0040	CHIEFTAIN TL36 - 1.25 cu.ft	3.0	1273.45	1443.75	1473.40	1495.00	1495.00	61.66	POA	POA	POA
8155.0025	HAWK TLB25 - 0.95 cu.ft	3.0	679.00	925.00	927.00	959.00	959.00	34.00	POA	POA	POA
8160.0030	MERCURY 30 - 1.06 cu.ft.	3.0	671.00	887.30	904.30	928.30	928.30	inc.	POA	POA	POA
8160.0040	AURORA 40 - 1.41 cu.ft.	3.0	771.00	987.30	1004.30	1028.30	1028.30	inc.	POA	POA	POA

## 13amp Plug & Fire Front-Loading Kilns

Code	13amp F/L Kiln	kW	Kiln Only	+ST312A	+ST314A	+ST315A	ST316A	Furniture Set	Spare Kiln Batt	Element Set	Delivery
8152.0036	FL36 - 1.42 cu.ft	3.0	1573.45	1743.75	1765.00	1795.00	N/A	61.66	POA	POA	POA
8168.0004	CU4 - 0.38 cu.ft.	3.0	892.00	1148.00	1170.00	1199.00	1199.00	N/A	N/A	POA	POA

## Hobby Kilns

Code	Hobby T/L Kiln	kW	Kiln Only	+ST312P	+ST314P	+ST315P	ST316P	Furniture Set	Spare Kiln Batt	Element Set	Delivery
8155.0040	HAWK 40 - 1.4cu.ft.	4.0	679.00	905.00	927.00	959.00	959.00	34.00	11.35	53.48	POA
8160.0060	COMET 60 - 2.1cu.ft.	5.5	956.73	1172.58	1189.58	1213.58	1213.58	inc.	POA	POA	POA

## Harrier Super Round Top-Loading Kilns

Code	Harrier Round T/L Kiln	kW	Kiln Only	+ST312A	+ST314A	+ST315A	ST316A	Furniture Set	Spare Kiln Batt	Element Set
8230.0075	SHTLB75 - 2.65 cu.ft	5.5	1144.00	1414.00	1436.00	1468.00	1468.00	59.00	22.32	80.49
8230.0112	SHTL115 - 4 cu.ft	7.0	1258.00	1528.00	1550.00	1581.00	1581.00	106.00	22.32	114.46
8230.0151	SHTL150 - 5.3 cu.ft	9.0	1399.00	1668.00	1690.00	1722.00	1722.00	121.00	35.35	154.03
8230.0226	SHTL233 - 7.9 cu.ft	11.25	1679.00	1949.00	1971.00	2002.00	2002.00	214.00	35.35	151.31
8230.0460	SHTL460 - 15.8 cu.ft.	18.25	2887.00	3157.00	3179.00	3211.00	3211.00	315.00	N/A	274.33

Kiln batt prices followed by a \* are half batt only. All other prices listed for spare kiln batts are whole round batts.

## Eco Round Top-Loading Kilns

Code	Eco Round T/L Kiln	kW	Kiln only	+ST312A	+ST314A	+ST315A	ST316A	Furniture Set A	Furniture Set B
8155.0040	eco40 - 1.41 cu.ft	3.0	1104.70	1275.00	1296.26	1329.25	1329.25	61.66	118.36
8155.0076	eco76 - 2.65 cu.ft.	6.0	1424.70	1995.00	1616.25	1646.25	1646.25	64.04	125.86
8155.0095	eco95 - 3.31 cu.ft	6.0	1524.70	1695.00	1716.25	1746.25	1746.25	65.23	138.64
8155.0103	eco103 - 3.6 cu.ft	7.0	1554.70	1725.00	1746.25	1776.25	1776.25	71.72	128.10
8155.0113	eco113 - 3.97 cu.ft	9.0	1609.70	1780.00	1801.25	1831.25	1831.25	66.41	148.36
8155.0128	eco128 - 4.49 cu.ft	9.0	1824.70	1995.00	2016.25	2046.25	2046.25	72.91	140.88
8155.0129	eco129 - 4.52 cu.ft	9.0	1929.70	2100.00	2121.25	2151.25	2151.25	90.38	201.84
8155.0152	eco152 - 5.32 cu.ft	9.0	1954.70	2125.00	2146.25	2176.25	2176.25	95.48	192.00
8155.0154	eco154 - 5.4 cu.ft	9.0	1979.70	2150.00	2171.25	2201.25	2201.25	74.09	150.60
8155.0161	eco161 - 5.65 cu.ft	10.0	2084.70	2255.00	2276.25	2306.25	2306.25	91.57	218.88
8155.0184	eco184 - 6.41 cu.ft.	11.0	2124.70	2295.00	2316.25	2346.25	2346.25	105.68	212.00
8155.0190	eco190 - 6.65 cu.ft	11.0	2179.70	2350.00	2371.25	2401.25	2401.25	96.67	209.04
8155.0193	eco193 - 6.77 cu.ft.	12.00	2224.70	2395.00	2416.25	2446.25	2446.25	92.75	231.84
8155.0228	eco228 - 7.98 cu.ft	13.0	2224.70	2395.00	2416.25	2446.25	2446.25	97.85	222.00
8155.0230	eco230 - 8.01 cu.ft.	13.0	2524.70	2695.00	2716.25	2746.25	2746.25	106.87	229.04
8155.0276	eco276 - 9.62 cu.ft	16.8	2624.70	2795.00	2816.25	2846.25	2846.25	108.05	242.00

Notes: Gas struts not available with eco40. Furniture Set - A = 2 kiln batts + props, Furniture Set - B = 4 kiln batts + props. All kilns include Overfire Protection as standard. Many optional extras available, these include 25mm secondary fibre insulation, Rolled stainless steel edges, Breaking castors and extra vent holes. Call for details.

## Chieftain Round Top-Loading Kilns

Code	Chieftain Round T/L Kiln	kW	Kiln only	+ST312A	+ST314A	+ST315A	+ST316A	Furniture Set
8150.0076	TL76 - 2.65 cu.ft	6.0	1678.45	1848.75	1878.40	1900.00	1900.00	132.00
8150.0095	TL95 - 3.31 cu.ft	6.0	1811.45	1981.75	2011.40	2033.00	2033.00	138.64
8150.0103	TL103 - 3.6 cu.ft	7.0	1847.45	2017.75	2047.40	2069.00	2069.00	128.10
8150.0113	TL113 - 3.97 cu.ft	9.0	1906.45	2076.75	2106.40	2128.00	2128.00	148.36
8150.0449	TL128 - 4.49 cu.ft	9.0	1973.45	2143.75	2173.40	2195.00	2195.00	140.88
8150.0129	TL129 - 4.52 cu.ft	9.0	2073.45	2243.75	2273.40	2295.00	2295.00	201.84
8150.0152	TL152 - 5.32 cu.ft	9.0	2104.45	2274.75	2304.40	2326.00	2326.00	192.00
8150.0154	TL154 - 5.4 cu.ft	9.0	2153.45	2323.75	2353.40	2375.00	2375.00	150.60
8150.0161	TL161 - 5.65 cu.ft	10.0	2273.45	2443.75	2473.40	2495.00	2495.00	218.88
8150.0184	TL184 - 6.41 cu.ft.	11.0	2347.45	2517.75	2547.00	2569.00	2569.00	212.00
8150.0190	TL190 - 6.65 cu.ft	11.0	2357.45	2527.75	2557.40	2579.00	2579.00	209.04
8150.0193	TL193 - 6.77 cu.ft.	12.00	2379.45	2549.75	2579.40	2601.00	2601.00	231.84
8150.0228	TL228 - 7.98 cu.ft	13.0	2743.45	2913.75	2943.40	2965.00	2965.00	222.00
8150.0230	TL230 - 8.01 cu.ft.	13.0	2768.45	2938.75	2968.40	2990.00	2990.00	229.04
8150.0276	TL276 - 9.62 cu.ft	16.8	2978.45	3148.75	3178.40	3200.00	3200.00	242.00

## Chieftain Oval Top-Loading Kilns

Code	Chieftain Oval T/L Kiln	kW	Kiln only	+ST312A	+ST314A	+ST315A	+ST316A	Furniture Set
8151.04	OTL04 - 4 cu.ft	9.0	2011.22	2181.52	2211.47	2232.77	2232.77	225.72
8151.05	OTL05 - 5 cu.ft	9.0	2217.13	2387.43	2417.08	2438.68	2438.68	283.88
8151.06	OTL06 - 6 cu.ft	9.0	2376.51	2546.81	2576.46	2598.06	2598.06	283.88
8151.07	OTL07 - 7 cu.ft	12.0	2504.63	2674.93	2704.58	2726.18	2726.18	295.84
8151.079	OTL07.9 - 7.9cu.ft	13.0	2659.61	2829.91	2859.56	2881.16	2881.16	332.20
8151.082	OTL08.2 - 8.2 cu.ft	13.0	2696.12	2866.42	2896.07	2917.67	2917.67	396.32
8151.09	OTL09 - 9 cu.ft.	15.0	2735.69	2905.99	2935.64	2957.24	2957.24	328.88
8151.010	OTL010 - 10 cu.ft	16.0	2968.67	3138.97	3168.62	3190.22	3190.22	370.76
8151.011	OTL011 - 11 cu.ft	18.0	3125.79	3296.09	3325.74	3347.34	3347.34	369.76
8151.012	OTL012 - 12 cu.ft.	18.0	3207.76	3378.06	3407.71	3429.31	3429.31	399.04
8151.013	OTL013 - 13 cu.ft	21.0	3246.62	3416.92	3446.57	3468.17	3468.17	389.20
8151.014	OTL014 - 14 cu.ft	24.0	3386.35	3556.65	3586.30	3607.90	3607.90	494.16
8151.015	OTL015 - 15 cu.ft.	24.0	3459.85	3630.15	3659.80	3681.40	3681.40	415.76
8151.016	OTL016 - 16 cu.ft	27.0	3551.92	3722.22	3751.87	3773.47	3773.47	638.24
8151.017	OTL017 - 17 cu.ft	29.0	3644.46	3814.76	3844.41	3866.01	3866.01	465.76
8151.018	OTL018 - 18 cu.ft	30.5	3747.68	3917.98	3947.63	3969.23	3969.23	638.24
8151.019	OTL019 - 19 cu.ft	31.5	3858.94	4029.24	4058.89	4080.49	4080.49	657.68
8151.020	OTL020 - 20 cu.ft	33.0	3961.00	4131.30	4160.95	4182.55	4182.55	584.80
8151.021	OTL021 - 21 cu.ft	35.0	4056.62	4226.92	4256.57	4278.17	4278.17	657.68
8151.023	OTL023- 23 cu.ft.	38.0	4345.04	4515.34	4544.99	4566.59	4566.59	728.88
8151.026	OTL026 - 26 cu.ft	43.0	4812.12	4982.42	5012.07	5033.67	5033.67	728.88

## Topworker Round Top-Loading Kilns

Code	Topworker Round T/L Kiln	kW	Kiln Only	+ST312	+ST314	+ST315	Furniture Set	Spare Kiln Batt	Element Set
8260.0079	TOPWORKER 80 - 2.8cu.ft	6.6	1196.00	1412.30	1429.30	1453.30	91.57		
8260.0120	TOPWORKER 120 - 4.2cu.ft.	8.8	1371.00	1587.30	1604.30	1628.30	178.06		
8260.0150	TOPWORKER 150 - 5.3cu.ft.	10.7	1651.00	1867.30	1884.30	1908.30	284.36		
8260.0190	TOPWORKER 190 - 6.6cu.ft.	12.0	1871.00	2087.30	2104.30	2128.30	284.36		
8260.0225	TOPWORKER 225 - 8cu.ft.	13.0	1971.00	2187.30	2204.30	2228.30	284.36		

We are pleased to quote for the delivery of any kilns or associated equipment. These deliveries are by pallet delivery service (with the exception of eco, Chieftain and Champion Kilns). Delivery will be to the nearest practicable point to the customer's premises. The carrier will off-load the pallet but removing the equipment from the pallet and moving into position is the responsibility of the customer. Deliveries of eco, Chieftain and Champion Kilns are carried out by the manufacturer. All prices quoted for these deliveries are for off-loading the kiln and moving into position. The price also includes installing to a suitable isolator (if available) and demonstrating kiln controller operation.

## Falcon 1300 Front-Loading Kilns

Code	Falcon 1300 F/L Kiln	kW	Kiln only	+ST312A	+ST314A	+ST315A	ST3 Auto Damper	Heat Lock	Furniture Set	1350° Upgrade	Element Set
8235.0053	FL3.1.50 - 1.87 cu.ft.	4.50(6.25)	1764.00	2032.00	2055.00	2088.00	370.00	419.00	55.00	90.00	101.56
8235.0066	FL3.1.65 - 2.34 cu.ft.	4.80(6.80)	1810.00	2078.00	2101.00	2134.00	370.00	419.00	66.00	88.00	116.45
8235.0079	FL3.1.80 - 2.81 cu.ft.	6.38(8.26)	1848.00	2116.00	2139.00	2172.00	370.00	419.00	94.00	70.00	108.81
8235.0122	FL3.1.20 - 4.31 cu.ft.	8.50(10.50)	2036.00	2304.00	2327.00	2360.00	370.00	419.00	147.00	105.00	106.68
8235.0163	FL3.1.60 - 5.75 cu.ft.	9.78(12.00)	2184.00	2452.00	2475.00	2508.00	370.00	419.00	194.00	81.00	166.28
8235.0171	FL171 - 6.1 cu.ft.	10.00(10.00)	2239.00	2507.00	2530.00	2563.00	370.00	419.00	194.00	110.00	POA
8235.0191	FL3.1.90 - 6.75 cu.ft.	11.38(13.50)	2292.00	2560.00	2583.00	2616.00	370.00	419.00	194.00	72.00	168.63
8235.0215	FL3.2.15 - 7.50 cu.ft.	12.75(15.00)	2539.00	2807.00	2830.00	2863.00	370.00	419.00	252.00	49.00	237.92
8235.0226	FL3.2.30 - 8 cu.ft.	12.75(15.00)	2827.00	3095.00	3118.00	3151.00	370.00	419.00	273.00	391.00	251.96
8235.0256	FL3.2.50 - 9 cu.ft.	14.23(16.50)	2690.00	2958.00	2981.00	3014.00	370.00	419.00	289.00	264.00	268.10
8235.0283	FL280 - 10 cu.ft.	15.75(17.25)	3500.00	3768.00	3791.00	3824.00	370.00	419.00	341.00	371.00	381.36
8235.0340	FL340 - 12 cu.ft.	18.00(20.00)	3937.00	4205.00	4228.00	4261.00	370.00	419.00	341.00	372.00	420.36
8235.0350	FL350 - 18.5 cu.ft.	18.50(20.50)	4180.00	4448.00	4471.00	4504.00	370.00	419.00	430.00	372.00	354.20
8235.0420	FL420 - 22 cu.ft.	22.00(24.00)	4397.00	4665.00	4688.00	4721.00	370.00	419.00	430.00	565.00	568.50
8235.0500	FL500 - 24.5 cu.ft.	24.50(26.50)	5062.00	5330.00	5353.00	5386.00	370.00	419.00	512.00	372.00	433.68

Note: If the 1350°C upgrade is chosen it should be noted that the kW rating of the kiln is increased to the value in brackets in the kW column.

## Falcon Compact VD 1300 Front-Loading Kilns

Code	Falcon Compact 1300 F/L Kiln	kW	Kiln only	+ST312A	+ST314A	+ST315A	+ ST3Auto Damper	Heat Lock	Furniture Set	Element Set
8240.0050	FLVD50 - 1.87 cu.ft.	4.5		3301.00	3325.00	3358.00	370.00	419.00	55.00	POA
8240.0065	FLVD66 - 2.34 cu.ft.	4.80		3343.00	3367.00	3400.00	370.00	419.00	66.00	POA
8240.0080	FLVD79 - 2.81 cu.ft.	6.38		3361.00	3385.00	3419.00	370.00	419.00	94.00	POA
8240.0120	FLVD122 - 4.31 cu.ft.	8.50		3687.00	3710.00	3742.00	370.00	419.00	147.00	POA
8240.0160	FLVD160 - 5.75 cu.ft.	9.78		3775.00	3798.00	3830.00	370.00	419.00	194.00	POA
8240.0190	FLVD190 - 6.75 cu.ft.	11.38		3943.00	3967.00	3997.00	370.00	419.00	194.00	POA
8240.0215	FLVD215 - 7.5 cu.ft.	12.75		4290.00	4313.00	4344.00	370.00	419.00	252.00	POA
8240.0230	FLVD230 - 8 cu.ft.*	12.75		5255.00	5278.00	5782.00	370.00	419.00	273.00	POA
8240.0250	FLVD250 - 9 cu.ft.	14.23		4396.00	4419.00	4451.00	370.00	419.00	289.00	POA

Note: Kiln marked \* is built with an arched roof.

## Falcon Compact CP1300 Front-Loading Kilns

Code	Falcon Compact F/L Kiln	kW	Kiln only	+ST312A	+ST314A	+ST315A	+ST3 Auto Damper	Heat Lock	Furniture Set	Element Set
8245.0050	FLCP50 - 1.87 cu.ft.	4.50		3232.00	3268.00	3340.00	370.00	419.00	55.00	
8245.0065	FLCP65 - 2.34 cu.ft.	4.80		3261.00	3298.00	3370.00	370.00	419.00	66.00	
8245.0080	FLCP80 - 2.81 cu.ft.	6.38		3292.00	3328.00	3401.00	370.00	419.00	94.00	
8245.0120	FLCP120 - 4.31 cu.ft.	8.50		3395.00	3430.00	3501.00	370.00	419.00	147.00	
8245.0160	FLCP160 - 5.75 cu.ft.	9.78		3493.00	3529.00	3598.00	370.00	419.00	194.00	
8245.0190	FLCP190 - 6.75 cu.ft.	11.38		3645.00	3679.00	3748.00	370.00	419.00	194.00	
8245.0215	FLCP215 - 7.5 cu.ft.	12.75		3963.00	3997.00	4067.00	370.00	419.00	252.00	
8245.0230	FLCP230 - 8 cu.ft.	12.75		4837.00	4871.00	4939.00	370.00	419.00	273.00	
8245.0250	FLCP250 - 9 cu.ft.	14.23		4094.00	4128.00	4196.00	370.00	419.00	289.00	

## Falcon Easi-Load Front-Loading Kilns

Code	Falcon Easi-Load F/L Kiln	kW	Kiln only	+ST312A	+ST314A	+ST315A	ST3 Auto Damper	Heat Lock	Furniture Set	1350° Upgrade	Element Set
8250.0120	SEL120 - 4.31cu.ft.	8.5(10.5)	3109.00	3376.00	3400.00	3433.00	370.00	529.00	147.00	243.00	POA
8250.0160	SEL160 - 5.75cu.ft.	9.76(12.00)	3166.00	3435.00	3458.00	3490.00	370.00	529.00	194.00	205.00	POA
8250.0190	SEL190 - 6.75cu.ft.	11.38(13.5)	3269.00	3554.00	3577.00	3612.00	370.00	529.00	194.00	259.00	POA
8250.0250	SEL250 - 9cu.ft.	14.08(16.5)	3654.00	3941.00	3964.00	3997.00	370.00	529.00	289.00	336.00	POA
8250.0230	SEL230 - 8cu.ft.	12.75(15.00)	4507.00	4792.00	4814.00	4849.00	370.00	529.00	273.00	85.00	POA
8250.0280	SEL280 - 10cu.ft.	15.25(17.25)	5276.00	5543.00	5568.00	5601.00	370.00	529.00	341.00	50.00	POA
8250.0340	SEL340 - 12cu.ft.	18.00(20.00)	5855.00	6141.00	6163.00	6196.00	370.00	529.00	341.00	34.00	POA
8250.0350	SEL350 - 12.5cu.ft.	18.50(20.5)	5992.00	6279.00	6301.00	6334.00	370.00	529.00	430.00	22.00	POA
8250.0420	SEL420 - 16cu.ft.	22.00(24.00)	6599.00	6885.00	6907.00	6946.00	370.00	529.00	430.00	65.00	POA
8250.0500	SEL500 - 18cu.ft.	24.50(26.50)	7068.00	7354.00	7376.00	7409.00	370.00	529.00	512.00	22.00	POA

Note: If the 1350°C upgrade is chosen it should be noted that the kW rating of the kiln is increased to the value in brackets in the kW column.

## Champion Front-Loading Kilns

Code	Champion F/L Kiln	kW	Kiln only	+ST312A	+ST314A	+ST315A	+ST316A	Furniture Set
8152.0036	FL36 - 1.42 cu.ft	3.0	1573.45	1743.75	1765.00	1795.00	1795.00	61.66
8152.0074	FL74 - 2.6 cu.ft	6.0	2190.45	2360.75	2382.00	2412.00	2412.00	186.00
8152.0096	FL96 - 3.37 cu.ft	6.0	2368.45	2538.75	2560.00	2590.00	2590.00	195.00
8152.0111	FL111 - 3.89 cu.ft	9.0	2703.45	2873.75	2895.00	2925.00	2925.00	205.00
8152.0129	FL129 - 4.5 cu.ft	9.0	2761.45	2931.75	2953.00	2983.00	2983.00	210.00
8152.0153	FL153 - 5.35 cu.ft	9.0	2820.45	2990.75	3012.00	3042.00	3042.00	275.00
8152.0171	FL171 - 6 cu.ft	12.0	2896.45	3066.75	3088.00	3118.00	3118.00	312.00
8152.0229	FL229 - 8 cu.ft	15.0	3551.45	3721.75	3743.00	3773.00	3773.00	312.00
8152.0286	FL286 - 10 cu.ft	18.0	4090.45	4260.75	4282.00	4312.00	4312.00	326.00
8152.0357	FL357 - 12.5 cu.ft	21.0	4927.45	5097.75	5119.00	5149.00	5149.00	425.00
8152.0429	FL429 - 15 cu.ft	24.0	5639.45	5809.75	5831.00	5861.00	5861.00	425.00
8152.0514	FL514 - 18 cu.ft	30.0	6602.45	6772.75	6794.00	6824.00	6824.00	POA
8152.0771	FL771 - 27 cu.ft	42.0	9759.45	9929.75	9951.00	9981.00	9981.00	POA

## Heaterwork Front-Loading Kilns

Code	Heatworker F/L Kiln	kW	Kiln only	+ST312	+ST314	+ST315	Furniture Set	Element Set
8250.0086	Heatworker 86 - 3 cu.ft.		1870.50	2242.45	POA	2297.28	130.73	POA
8250.0128	Heatworker 128 - 4.5 cu.ft		2087.65	2416.60	POA	2476.80	174.38	POA
8250.0171	Heatworker 171 - 6 cu.ft		2247.83	2577.85	POA	2642.35	180.82	POA

Note: All kilns in this range have elements mounted on ceramic tubes

## Ceramaster Front-Loading Kilns

Code	Ceramaster F/L Kiln	kW	Kiln only	+ST312	+ST314	+ST315	Furniture Set	Element Set
8255.0235	Ceramaster 235 - 8.3cu.ft.	13.0	3142.23	POA	POA	3457.20	409.66	POA
8255.0285	Ceramaster 285 - 10.1cu.ft	15.2	3786.15	POA	POA	4085.00	517.65	POA
8255.0325	Ceramaster 325 - 11.5cu.ft	18.0	4249.48	POA	POA	4549.40	585.89	POA
8255.0435	Ceramaster 435 - 15.4cu.ft.	22.0	5065.40	POA	POA	5364.25	590.10	POA
8255.0505	Ceramaster 505 - 17.8cu.ft.	26.5	5801.78	POA	POA	6101.70	598.50	POA
8255.0600	Ceramaster 600 - 21.2cu.ft.	30.0	7591.65	POA	POA	7775.48	612.44	POA

Note: All kilns in this range have elements mounted on ceramic tubes.

## Rocket Raku Kilns

Code	Rocket Raku Kiln	Kiln	Kiln & Burner
8110.0037	ROCKET 37 - 1.32 cu.ft	699.00	904.06
8110.0055	ROCKET 55 - 1.98 cu.ft.	746.00	951.06
8110.0074	ROCKET 74 - 2.65 cu.ft.	763.00	973.00
8110.0101	ROCKET 101 - 3.6 cu.ft.	801.00	1011.60
8110.0121	ROCKET 121 - 4.32 cu.ft.	890.00	1105.40
8110.0148	ROCKET 148 - 5.32 cu.ft.	905.00	1120.40

Code	Rocket Raku Kiln Extension Rings	Ring
8110.1137	RX37 for kiln RR37, RR55, RR74	167.52
8110.1150	RX50 for kiln RR101	193.00
8110.1160	RX60 for kiln RR121	238.09
8110.1174	RX74 for kiln RR148	245.64

## Champion Front-loading Gas Kilns

Code	Champion F/L Kiln	BTU's	Kiln	Furniture Set	Spare Kiln Batt
8230.0055	CG55 - 1.95 cu.ft	45k	2746.00	205.00	POA
8230.0096	CG96 - 3.37 cu.ft	50k	2916.00	229.00	POA
8230.0153	CG153 - 5.35 cu.ft	75k	3863.00	267.00	POA
8230.0229	CG229 - 8 cu.ft.	116k	5346.00	289.00	POA
8230.0290	CG290 - 10 cu.ft	144k	6192.00	294.00	POA
8230.0363	CG363 - 12.7 cu.ft.	190k	7944.00	495.00	POA
8230.0447	CG447 - 15.6 cu.ft.	250k	10311.00	POA	POA
8230.0772	CG772 - 27 cu.ft.	390k	POA	POA	POA
8230.1830	CG1830 - 64 cu.ft.	785k	POA	POA	POA

# Glass Kilns

## GF Range Top-Loading Kilns - 860°C

Code	GF T/L Kiln - 860°C	kW	Kiln only	+ST314K	+ST316K
8260.0013	GF13	2		879.00	909.00
8260.0045	GF45	4		1172.00	1203.00
8260.0090	GF90	7		1552.00	1582.00

## GC Range Top-Loading Kilns - 1060°C

Code	GC T/L Kiln - 1060°C	kW	Kiln only	+ST314K	+ST316K	+ST501K
8263.0025	GC25	3		938.00	966.00	1004.00
8263.0040	GC40	4		1045.00	1073.00	1111.00
8263.0075	GC75	5		1479.00	1505.00	1545.00
8263.0115	GC115	7.0		1587.00	1613.00	1676.00
8263.0150	GC150	9.0		1732.00	1759.00	1811.00
8263.0220	GC220	11.25		2013.00	2039.00	2097.00

## GF Flatbed Fusing & Slumping Range Top-Loading Kilns - 1000°C

Code	GF Flatbed T/L Kiln - 1000°C	kW	Kiln only	+ST314	+ST315	+ST316
8264.0055	GF55FBD	3.0		2163.00	2185.00	2185.00
8265.0155	GF155FBD	7.0		3185.00	3207.00	3207.00

## GF Flatbed Fusing & Slumping Range Top-Loading Kilns - 1060°C

Code	GF Flatbed T/L Kiln - 1060°C	kW	Kiln only	+ST314A	+ST315A	+ST316A	+ST501A	Furniture Set
8265.0075	GF75FB	6.0		2185.00	2218.00	2218.00	2364.00	
8265.0250	GF250FB	9.0		3207.00	3239.00	3239.00	3282.00	
8265.0350	GF350FB	11.0		3601.00	3531.00	3531.00	3542.00	
8265.0500	GF500FB	12.0		4028.00	4029.00	4029.00	4103.00	
8265.0800	GF800FB	16.0		5515.00	5543.00	5543.00	5596.00	
8265.1500	GF1500FB	22.0		7808.00	7839.00	7839.00	7883.00	

# Kiln Accessories

For information on selecting cones please refer to Page 38

## Kiln Controllers

Code	Kiln Controllers	Each
8657/1	ST221 Single program plug-in controller	208.00
8657/2	ST222 - 9 program, 9 segment plug-in controller	221.00
8657/3	ST222 KILN TEMP PROGRAMMER + 6" THERMO	
8654	ST312A - Single program/2 ramp	172.00
8655	ST315A - 9 program, 9 segments	213.00
8656	ST316A - 9 program, 9 segments	213.00
8659	ST325 - 32 program, 32 segment controller	295.00
8660	ST326 - 99 program controller	295.00
8641	ST501A - 20 program, 30 segment controller	245.00
8610/2	8pin HARTING PLUG + 2m CABLE	29.00
8610/3	8pin HARTING PLUG + 3m CABLE	33.17

Note: Multi-zone versions of the ST325 & 326 are available. Prices on request.

## Kiln Controller Additions

Code	Kiln Controller Additions	Each
8790	HARTING SOCKET + 2m CABLE	23.00
8793	RC FILTER NETWORK SUPPRESSOR	4.59

Note: 8657/3 ST222 Kiln Temperature Programmer + 6" thermo is ideal for fitting easily to any kiln with a kiln-sitter to give you most of the facilities of a kiln with a dedicated kiln controller. Ideal for glass, enamelling and general ceramics. 9 programs, each with 9 segments. 1 controlled heating/cooling ramp plus 1 soak per segment.

We now list the prices for ST controllers without cable and plug for fitting to kilns with 8 pin harting sockets. If ordering a ST controller for fitting in this way order the controller and a Harting Plug and cable, which would be then be factory fitted for immediate use. (i.e. 8655 - ST315A + 8610 Harting Plug & 2m cable)

## Kiln Furniture

Code	Kiln Furniture	Each	x 12
8406	1" TUBULAR PROP	1.25	9.60
8400	2" TUBULAR PROP	1.25	13.80
8401	4" TUBULAR PROP	1.58	17.28
8402	6" TUBULAR PROP	2.42	27.32
8403	8" TUBULAR PROP	3.03	34.25
8404	10" TUBULAR PROP	3.64	41.40
8405	12" TUBULAR PROP	3.90	44.52
8407	INTER-CONNECTOR	1.17	13.27
8410	1" CASTELLATED PROP	0.91	10.30
8411	1.5" CASTELLATED PROP	1.12	12.67
8412	0.5" INTERLOCKING EXTENSION PROP	1.49	16.83
8413	1" INTERLOCKING EXTENSION PROP	1.55	15.24
8414	TUBULAR BASE	2.77	31.56

## Indicators

Code	Indicators	Each
8304	PORTABLE DIGITAL PYROMETER	82.00

## Thermocouples

Code	Thermocouples	Each
8310	5.5" BRACKET ENDED - "R" type	59.29
8310/S	5.5" BRACKET ENDED - "S" type	59.29
8311	7.5" BRACKET ENDED - "R" type	71.53
8312	9" BRACKET ENDED - "R" type	80.70
8318	7" LAB HEAD - "R" type	PO.A
8316	6" MINERAL INSULATED METAL SHEATH - "K" type	37.08

Other thermocouple sizes and types available to order

## Kiln Batts (Shelves - Circular)

Code	Kiln Batts (Shelves - Circular)	Each
570.8050.11375.1	11.5" ROUND	9.32
570.8050.12.1	12.625" ROUND	13.45
570.8050.13.1	13" ROUND	11.42
570.8050.145.1	14.5" ROUND	18.65
570.8050.145.2	14.5" HALF ROUND	12.15
570.8050.1525.1	15.25" ROUND	26.75
570.8050.165.1	16.5" ROUND	22.32
570.8050.165.2	16.5" HALF ROUND	12.86
570.8050.21.1	21" ROUND	34.86
570.8050.21.2	21" HALF ROUND	19.58
570.8050.23.1	23" HALF ROUND	35.35
570.8050.23.2	23" ROUND	36.21

## Kiln Batts (Shelves - Rectangular)

Code	Kiln Batts (Shelves - Rectangular)	Each
570.8052.1711.1	17 x 11 x 1"	19.15
570.8052.1711.2	17 x 11 x 0.75"	19.15
570.8052.2211.1	22 x 11 x 1"	25.78

## Kiln Batts (Shelves - Square)

Code	Kiln Batts (Shelves - Square)	Each
570.8052.1212.1	12 x 12 x 0.5"	12.22

## Cones & Accessories

Code	Cones & Accessories	Pack	x 50
8600	ORTON STANDARD CONES	2.35	10.20
8615	ORTON PYRO-BARS	2.85	7.47
8610	ORTON MIDGET CONES (While stocks last)		2.50
8601	TRIPLE CONE SOCKET	1.25	

## Ceramic Stilts & Pins

Code	Ceramic Stilts & Pins	Each	x 12
8500	01 STILT	0.35	3.60
8501	02 STILT	0.45	4.80
8502	03 STILT	0.54	4.92
8503	04 STILT	0.70	6.60
8504	05 STILT	0.89	9.18
8505	06 STILT	1.40	13.80
8506	07 STILT	1.55	15.00
8530	SADDLES/PINS - 1"	0.09	
8531	SADDLES/PINS - 2"	0.12	

## Metal Pointed Stilts

Code	Metal Pointed Stilts	Each	x 6
8540/1	3 pin STILT - Pin to Pin 14mm x 4mm high	1.14	6.12
8540/2	3 pin STILT - Pin to Pin 22mm x 6.3mm high	1.23	6.54
8540/3	3 pin STILT - Pin to Pin 33mm x 8mm high	1.45	7.68
8540/4	3 pin STILT - Pin to Pin 43mm x 10mm high	1.62	7.62
8540/5	3 pin STILT - Pin to Pin 51mm to 12mm high	2.04	8.58
8540/6	2 x 3 pin STILT	2.72	14.40
8541/1	3 pin STILT - Pin to Pin 38mm x 3mm high	1.95	9.24
8541/2	3 pin STILT - Pin to Pin 49mm x 4mm high	2.23	10.56
8541/3	3 pin STILT - Pin to Pin 55mm x 5mm high	2.66	12.60

## Bricks

Code	Bricks	Each	x 20
8945	JM23 BRICK (9 x 4.5 x 3")	6.00	65.00
8946	JM26 BRICK (9 x 4.5 x 3")	4.50	44.10

## Ceramic Fibre Papers

Code	Ceramic Fibre Paper	610 x 300mm	Roll
8942	SUPERWOOL 607 PAPER (1mm x 610mm x 40m)	N/A	N/A
8944	FIBERFRAX PAPER (1mm x 610mm x 40m)	1.83	117.44

## Ceramic Fibre Blanket

Code	Ceramic Fibre Blanket	610 x 300mm	Roll
8948	SUPERWOOL 607 MAX (13mm x 610mm x 14.64m)	2.41	88.76
8949	SUPERWOOL 607 MAX (25mm x 610mm x 7.32m)	5.70	89.25

## Refractory Sundries

Code	Refractory Sundries - Liquid	500ml	5 litres
8935	FIBER HARDENER	5.10	43.29

Code	Refractory Sundries	500g	1kg	Tub
8937	BR6 REFRACTORY CEMENT	2.25	3.40	20.40
8939	BR5 REFRACTORY CEMENT	2.12	3.20	33.45

Note: A tub of 8937 - BR6 contains 5 litres (approx. 12.5kg cement). A tub of 8939 - BR5 contains 10 litres (approx. 25kg cement).

## Sundries

Code	Sundries	Each
8700	NICHROME WIRE - 19swg	4.75
8705	KEVLAR MITT	16.80
8705/1	HEAT RESISTANT GLOVE	POA
8710/1	RAKU TONGS	12.95
8711	ABRASIVE STONE	3.75
5100	ALUMINA HYDRATE x 500g	2.63
5111	BATT WASH - 500g	3.10

# HARRIER TOP-LOADING KILNS



Equally at home in a studio or industrial environment, the Harrier Range of electric kilns is a cost effective firing solution. All kilns in the range provide excellent temperature control for a variety of products and are available with a wide choice of plug-in temperature controllers to suit individual requirements.



For more information on Harrier Top-Loading Kilns and all our Kilns & Accessories please refer to our **Kiln Book**

# Plaster Moulds

Plaster Moulds



Code	Plaster Moulds	Each
4901	PLASTER SINK	32.10
4930	CIRCULAR PRESS	26.88
4931	CIRCULAR HUMP	DISC.
4932	OVAL PRESS	27.95
4933	OVAL HUMP	DISC.
4934	SQUARE PRESS	27.95
4935	SQUARE HUMP	DISC.
4936	RECTANGULAR PRESS	27.95
4937	RECTANGULAR HUMP	DISC.

All our press and hump moulds are made from Keramicast Plaster for durability and longer life.

4930  
CIRCULAR PRESS MOULD



4932  
OVAL PRESS MOULD



4934  
SQUARE PRESS MOULD



4936  
RECTANGULAR PRESS MOULD



## Related Tools

Code	Related Tools	Each
6317	MOULD TRIMMING TOOL	0.95
4920/12	MOULD NATCHES - 0.375" (3/8") x 12	1.00

## Related Materials

Code	Related Materials	Each
5225	MOULDMAKERS SIZE - 500g	4.41

# Plasters

## Casting Plasters

Code	Casting Plaster	Mixing Ratio	1kg	5kg	25kg	50kg	125kg	250kg	500kg	1000kg	1050kg**	1400kg**
4001	FINE CASTING *											295.94
4006	FINE CASTING PLUS	100/70	-	4.03	10.07	18.08	43.90	77.50	144.60	258.00		299.30
4030	HERCULITE 2	100/42	-	5.39	16.75	31.70	76.95	135.80	253.60	452.80		560.83
4033	CRYSTACAL R*	100/35	-									742.94
4034	CRYSTACAST	100/28	-	9.19	35.81	67.64	159.15	298.40	557.00	994.80		1209.79
4035	CRYSTACAL ALPHA K	100/21	-	14.11	44.29	85.30	213.25	436.30	819.80			
4050	HERCULITE LX*	100/40										1005.52
4052	HERCULITE STONE*	100/33										
4068	CRYSTACAL LAMINA*	100/35										1446.61

Plasters followed by a \* are to order only.

## Ceramic Industry Plasters

Code	Ceramic Industry Plaster	Mixing Ratio	1kg	5kg	25kg	50kg	125kg	250kg	500kg	1000kg	1050kg**	1400kg**
4002	SUPERFINE PLASTER*											434.36
4003	POTTERS PLASTER	100/65	-	3.96	9.67	17.36	42.15	74.40	138.80	248.00		285.59
4005	NEWCAST 71/80 PLASTER*											342.96
4020	KERAMICAST	100/60	0.92	4.57	13.08	23.48	57.00	100.60	187.80	335.20		402.98
4021	ULTRAMIX*											924.01

Plasters followed by a \* are to order only.

## Dental Profession Plasters

Code	Dental Profession Plaster	Mixing Ratio	1kg	5kg	25kg	50kg	125kg	250kg	500kg	1000kg	1050kg**	1400kg**
4011	DENTAL*	100/60										470.82
4012	SURGICAL*	100/60										538.64
4071	DENSTONE KD*	100/30										999.98

Plasters followed by a \* are to order only.

Note: For bulk orders 4035 Crystacal Alpha K can only be packed to a maximum of 20 tubs (500kg) to a pallet. This incurs a charge for a full 1000kg pallet.

Note: All weights followed by \*\* are whole pallets only.

Note: All 1050kg & 1400kg pallet prices are ex-works Newark, Nottinghamshire. Collections can be made, but please check in advance for details of safety clothing that must be worn and for available bookings.



# Books

## General

Code	General	Each
9003	POTTERS TIPS - CPA	8.95
9010	POTTERY BASICS	14.99
9011	INTRODUCING POTTERY: THE COMPLETE GUIDE	19.99

## Kilns & Firing

Code	Kilns & Firing	Each
9601	THE ELECTRIC KILN	15.99
9603	KILN BUILDING	15.99
9608	RAKU	35.00
9609	SINGLE FIRING	15.99
9613	RAKU - INVESTIGATION IN TO FIRE	25.00
9615	RAKU	15.99
9616	ALTERNATIVE KILN	15.99
9621	SMOKE FIRING	30.00
9622	FIRING: PHILOSOPHIES WITHIN CONT. CERAMICS	25.00

## Making Techniques

Code	Making Techniques	Each
9500	COILED POTTERY	14.99
9503	THROWING POTS	15.99
9506	LARGE SCALE CERAMICS	15.99
9514	HANDBUILDING	15.99
9533	THE COMPLETE POTTER	14.99
9539	COILING	15.99
9540	WHEEL THROWN POTTERY	O/P
9542	THE POTTER'S BIBLE	12.99
9543	THE BASICS OF THROWING	16.99
9544	CLAY, LIGHT & WATER	15.99
9545	LOW-FIRING & BURNISHING	15.99
9546	CERAMIC JEWELLERY	15.99
9547	SLAB TECHNIQUES	15.99
9548	THROWING LARGE	15.99

# Our Recommendations

## General Overview Books

9533

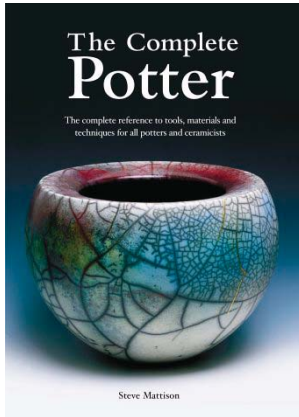

This definitive guide takes you through all the processes from clay to kiln: from designing your own pieces, to making, decorating and firing them. The book is clearly laid out and packed with factual information that creative ceramists will want to have to hand, including descriptions of the very latest materials, and instructions on how to use them effectively in your work. Step-by-step instructions for traditional methods and new products, such as paper-clay and print-on-clay, are combined with examples of work by some of the world's top ceramicists and details of how they achieve their results.

9578

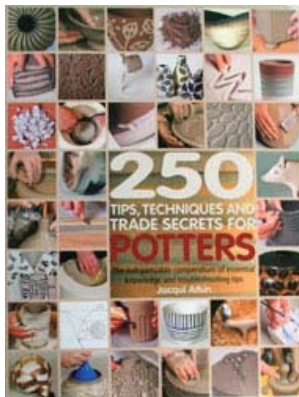

This is a troubleshooting book filled with tips and handy advice for the beginner and intermediate potter. The information is arranged in easy-to-follow, step-by-step sections which are illustrated with line drawings and photographs. The subjects include: clays, tools and equipment, making techniques, designing shapes and surface decoration. The text is very accessible and the layout easy to navigate. The result is a book that should be a must for the reference shelves of all beginning and intermediate potters.

9010

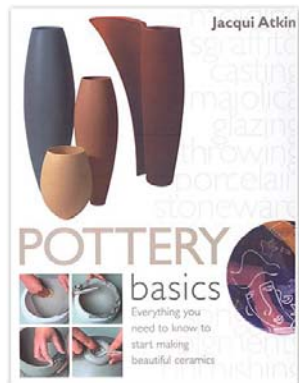

This book is a basic introduction to pottery. It covers everything the beginner needs to know to start making beautiful ceramics. Step-by-step photographs and clear instructions guide you through the techniques for making, decorating, and firing pottery and twelve simple projects allow you to put your skills into practice. Chapters include an introduction to types of clay, basic modelling methods such as throwing, pinching, coiling and turning. Key techniques are taught for biscuit and glaze firing. Each progressive project develops a new skill, and then teaches you how to add texture and decorate your vessels using inlays, slips, sgraffito, feathering, burnishing and resist techniques.

9542

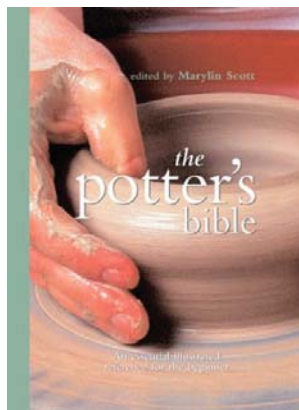

This is a highly illustrated reference for beginner potters, covering all the basics they would need to do a wide range of ceramics. The book is filled with step-by-step photographic sequences which take the reader through all the basic shaping, firing and decorating techniques they would need to know. The book is in the useful wire binding format so that the book can be laid flat so that readers can follow the sequences while making their work.

## Slip Casting

Code	Slip Casting	Each
9700	SLIPCASTING	15.99



## Reference

Code	Reference	Each
9037	THE CERAMIC PROCESS	40.00
9038	CERAMICS & THE ENVIRONMENT	35.00
9050/5	DICTIONARY OF MATERIALS & TECHNIQUES - 5th Ed.	45.00
9053	CERAMIC FAULTS & REMEDIES	17.99
9067	SETTING UP A POTTERY WORKSHOP	15.99
9087/PB	SOURCES OF INSPIRATION	19.99

## Magazines

Code	Magazines	Each
9400	CERAMIC REVIEW	6.30

Please Note: 15% Discount is only applicable on past copies of Ceramic Review which we may have in stock.

## Plaster, Mouldmaking & Sculpture

Code	Plaster, Mouldmaking & Sculpture	Each
9403	MODELLING THE FIGURE IN CLAY	16.99
9404	MODELLING THE HEAD IN CLAY	16.99
9407	MODELLING IN CLAY & OTHER MATERIALS	15.99
9409	MOULDMAKING	15.99
9412	THE PORTRAIT IN CLAY	18.99
9418	CERAMICS FIGURES	17.50
9419	THE FIGURE IN FIRED CLAY	28.00
9426	SCULPTING BASICS	14.99
9429	THE SCULPTURE'S BIBLE	16.99
9432	THE BIBLE OF SCULPTING TECHNIQUES	12.99
9434	WALL PIECES	15.99

## Beginners, Children & Education

Code	Beginners, Children & Education	Each
9200	CLAY IN THE PRIMARY SCHOOL	12.99
9202	EXPLORING CLAY WITH CHILDREN	12.99
9203	SCULPTURAL MATERIALS IN THE CLASSROOM	12.99
9205	CLAY FOR PEOPLE WITH SPECIAL NEEDS	15.99
9206	CLAY PROJECT FOR CHILDREN	14.99

# Our Recommendations

## Glaze Books

9125

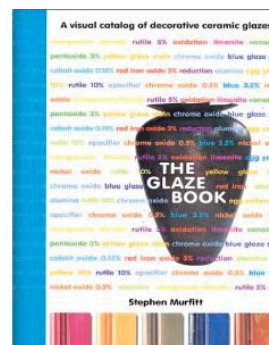

Readers will find anything and everything they want to know about glazes in this one practical and workshop-friendly volume. More than 1,000 glazes are illustrated so readers can see the colour and surface response each offers. The book covers utilitarian domestic ware and decorative ceramics, as well as firing and glazing techniques for both. It also features valuable information on preparation, application techniques, health and safety considerations, and kiln firing cycles.

## Clays & Glazes



Code	Clay & Glazes	Each
9101	CLAYS & GLAZES - CPA	14.95
9108	CRYSTALLINE GLAZES	14.99
9109	SODA GLAZING	9.99
9110	PAPER CLAY	15.99
9114	COLOUR IN CLAY	25.00
9121	PORCELAIN	15.99
9122	GLAZES: CONE 6	15.99
9125	THE GLAZE BOOK	19.95
9126	POTTER'S GUIDE TO CERAMIC SURFACES	16.99
9129	STONEWARE	14.99
9132	POTTER'S BOOK OF GLAZE RECIPES	19.99
9134	ORIENTAL GLAZES	15.99
9136	NAKED CLAY	19.99
9141	COLOURING CLAY	15.99
9142	DRY GLAZES	15.99

## Miscellaneous

Code	Miscellaneous	Each
9877	SELLING YOUR CRAFTS	13.95
9897	ARTIST'S GUIDE TO SELLING WORK	9.99

## Decorating Techniques

Code	Decorating Techniques	Each
9556	CERAMICS & PRINT	15.99
9557	RESIST & MASKING TECHNIQUES	15.99
9558	IMPRESSED & INCISED CERAMICS	14.99
9573	LETTERING ON CERAMICS	15.99
9576	CERAMIC & MIXED MEDIA	15.99
9578	250 TIPS, TECHNIQUES & TRADE SECRETS	16.99
9579	SURFACES & TEXTURES	19.99
9582	MAJOLICA	15.99
9583	TECHNIQUES USING SLIPS	16.99

## Our Recommendations

### Sculpture Books

9403

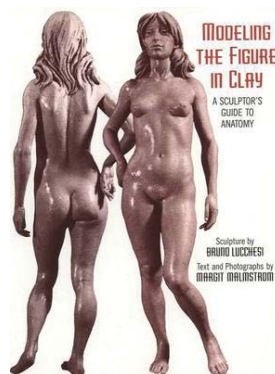

For thirty years, *Modeling the Figure in Clay* has been an indispensable anatomical resource for people who think, see, and understand form best in the round: sculptors. Master sculptor Bruno Lucchesi invites you on a guided tour of the human form. Follow him as he creates a figure in clay—literally from the inside out—starting with the skeleton, laying on the muscles to show male and female anatomy, and finishing with a complete figure sculpture with every detail of face and hair carefully modelled.

9404

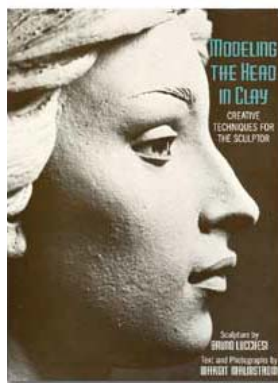

Renowned contemporary sculptor Bruno Lucchesi takes a single life-size head through all the stages of rough in, modeling, refining the surface, and finishing and texturing, enabling the reader to see exactly how he positions and models every detail. The book demonstrates not just highlights of the creative process, but every step from beginning to end.

## Our Recommendations

### Ceramics Handbooks

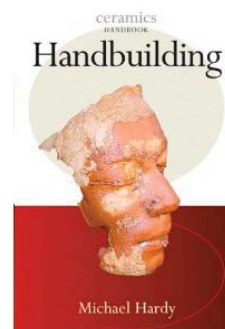
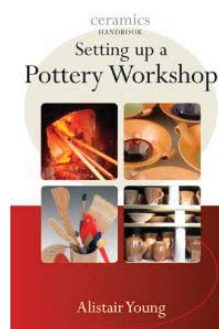
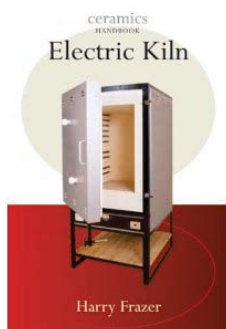
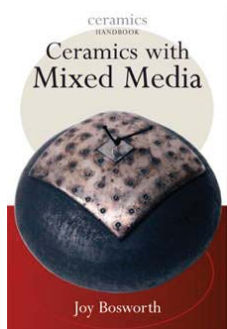
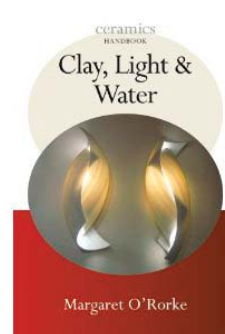
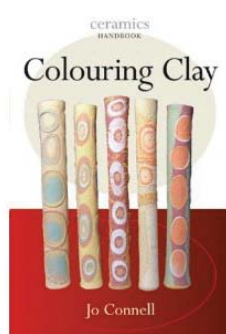
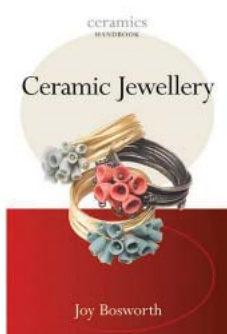



## Bisque Tiles

Code	Bisque Tiles	Each	Case
600.07.280	WHITE TILE 6 x 6" (Case 24)	0.83	18.00
600.07.281	WHITE TILE 4 x 4" (Case 12)	0.43	3.96
600.07.282	BUFF TILE 6 x 6" (Case 12)	0.76	6.12
600.08.442	4" TILE - WHITE (Case 10)	0.36	2.40
600.07.384	6" TILE - WHITE (Case 8)	0.84	4.56
600.07.383	8" TILE - WHITE (Case 8)	1.22	6.56

## Alpha Numeric Bisque

Code	Alpha Numeric	Each	Case (x20)
600.07.772-A	LETTER A	0.23	3.40
600.07.772-B	LETTER B	0.23	3.40
600.07.772-C	LETTER C	0.23	3.40
600.07.772-D	LETTER D	0.23	3.40
600.07.772-E	LETTER E	0.23	3.40
600.07.772-F	LETTER F	0.23	3.40
600.07.772-G	LETTER G	0.23	3.40
600.07.772-H	LETTER H	0.23	3.40
600.07.772-I	LETTER I	0.23	3.40
600.07.772-J	LETTER J	0.23	3.40
600.07.772-K	LETTER K	0.23	3.40
600.07.772-L	LETTER L	0.23	3.40
600.07.772-M	LETTER M	0.23	3.40
600.07.772-N	LETTER N	0.23	3.40
600.07.772-O	LETTER O	0.23	3.40
600.07.772-P	LETTER P	0.23	3.40
600.07.772-Q	LETTER Q	0.23	3.40
600.07.772-R	LETTER R	0.23	3.40
600.07.772-S	LETTER S	0.23	3.40
600.07.772-T	LETTER T	0.23	3.40
600.07.772-U	LETTER U	0.23	3.40
600.07.772-V	LETTER V	0.23	3.40
600.07.772-W	LETTER W	0.23	3.40
600.07.772-X	LETTER X	0.23	3.40
600.07.772-Y	LETTER Y	0.23	3.40
600.07.772-Z	LETTER Z	0.23	3.40
600.07.773-0	NUMBER 0	0.23	3.40
600.07.773-1	NUMBER 1	0.23	3.40
600.07.773-2	NUMBER 2	0.23	3.40
600.07.773-3	NUMBER 3	0.23	3.40
600.07.773-4	NUMBER 4	0.23	3.40
600.07.773-5	NUMBER 5	0.23	3.40
600.07.773-6	NUMBER 6	0.23	3.40
600.07.773-7	NUMBER 7	0.23	3.40
600.07.773-8	NUMBER 8	0.23	3.40
600.07.773-9	NUMBER 9	0.23	3.40

## Dishware & Kitchenware

Code	Dishware & Kitchenware	Each	Case
600.02.360	9.75" PLATTER / BOWL (Case 6)	3.68	12.72
600.03.266	10.25" SQUARE SERVING BOWL (Case 4)	1.28	2.96
600.04.538	11" PLATTER / BOWL (Case 3)	2.26	3.90
600.04.905	OIL BOTTLE (Case 6)	2.64	9.12
600.07.099	ICE CREAM / DESSERT BOWL - LGE (Case 6)	2.32	7.98
600.0052C	ROOSTER TEAPOT (Case 6)	DISC.	
600.03.698	WAVY RIM PLATTER/BOWL (Case 4)	0.94	2.16
600.04.540	13" PLATTER (Case 4)	1.48	3.40
600.05.661	HEART BOWL (Case 4)	1.88	8.64
600.07.764	CEREAL BOWL (Case 6)	1.78	6.12
600.08.170	HEART COASTER (Case 12)	0.76	5.28
600.08.427	RIM DINNER PLATE (Case 6)	2.46	8.46
600.08.500	COUPE CHARGER PLATE	3.00	10.38

## Mugs & Cups

Code	Mugs & Cups	Each	Case
600.06.525	CLASSIC MUG (Case 6)	2.58	8.88
600.04.989	FLARE MUG (Case 8)	4.04	18.56
600.06.624	5" T BARREL MUG (Case 8)	2.26	10.40
600.05.637	TALL FLARE MUG (Case 6)	1.54	5.34
600.07.083	CONE MUG (Case 6)	1.66	5.70
600.07.748	12oz MUG (Case 6)	1.34	4.62
600.07.756	LATTE MUG (Case 6)	1.44	4.98
600.07.365	MARTINI GLASS (Case 6)	1.70	5.88

## Home & Garden

Code	Home & Garden	Each	Case
600.02.752	MEDIUM SQUARE VASE (Case 8)	2.90	13.36
600.03.367	TALL CURVY VASE	1.96	9.04
600.04.880	5" MODERN VASE (Case 6)	2.42	8.34
600.06.693	BASKET (Case 4)	1.96	9.04
600.02.372	HEART SHAPE VASE (Case 8)	0.76	3.52
600.04.046	LARGE RECTANGULAR VASE (Case 4)	0.80	3.68
600.04.241	SQUARE FLOWER POT (Case 4)	0.68	3.12
600.04.193	DRAGONFLY P. POURRI BURNER (Case 8)	0.70	3.20
600.05.593	DOLPHIN TEALIGHT HOLDER (Case 8)	1.12	5.12

## Kids & Gifts

Code	Kids & Gifts	Each	Case
600.08.358-8	SAILBOAT ADD-ON 3D (Case 20)	0.24	2.80
600.05.771	BULLDOG PUPPY (Case 8)	1.46	7.04
600.06.645	BABY SNAIL (Case 12)	0.90	6.48
600.07.075	LUCKY CAT (Case 6)	1.60	5.76
600.07.259	PUPPY DOG - MEDIUM (Case 8)	1.54	7.36
600.07.260	FIRE DRAGON (Case 4)	2.38	5.72
600.06.643	BABY LION (Case 12)	2.10	15.12
600.06.649	SQUIRREL (Case 12)	1.74	12.48
600.06.707	TUMBLER LADYBUG (Case 12)	0.68	4.92
600.07.070	ALLIGATOR HATCH. FROM EGG (Case 6)	2.04	7.32
600.07.123	STRETCHING CAT	0.74	5.28
600.07.379	CUTE BUTTERFLY (Case 12)	0.70	5.04
600.07.405	RACE CAR (Case 8)	1.36	6.56
600.07.400	TRICERATOPS (Case 6)	0.76	2.76
600.08.169	GNOME (Case 8)	1.60	7.68
600.08.08.214	SLEEPING CAT (Case 6)	0.90	3.24
600.08.457	MEDIUM GECKO (Case 6)	1.62	5.82

## Savings Bank

Code	Savings Bank	Each	Case
600.05.1163	SQUARE BUTTERFLY BANK (Case 8)	3.86	18.56
600.06.717	TRAIN BANK (Case 8)	1.78	8.56
600.07.294	CROWN BANK (Case 6)	3.04	10.92
600.08.225	SMALL PIGGY BANK (Case 6)	1.54	5.52

## Miscellaneous

Code	Miscellaneous	Each	Case
600.07.567	COLOUR CHART CHIPS	0.20	

## MUGS & CUPS



### Boxes

Code	Boxes	Each	Case
600.04.1010	BIRTHDAY CAKE BOX (Case 6)	4.04	13.92
600.04.887	SMALL ROUND BOX (Case 8)	0.70	2.40
600.06.697	ICE CREAM CONE BOX (Case 6)	1.36	4.68
600.06.699MS	STAR BOX SET (OF 2) (Case 4)	3.28	15.12
600.07.378	CUPCAKE BOX (Case 6)	1.36	4.68
600.05.046	SMALL ROUND GIFT BOX (Case 6)	1.52	5.22
600.07.392	SANDAL BOX		
600.08.139	PIANO BOX (Case 6)	2.50	8.64



For images & more information on all our Bisque please refer to our

### Bisque Book

Our Chrysanthos Café Colours are formulated for use with our Bisque. Please refer to Page 15

## When space is a problem take a look at our Falcon Compact VD & CP Range of Kilns



See prices on page 28

# Cone Selector Guide

The composition and structure of cones is such that they bend and deform when subjected to heat for a period of time, (i.e. their operation is dependent upon "heat work" and not upon temperature only. They are graded according to the amount of heat they will withstand and are placed upright in holders in the kiln where they can be viewed from the spy hole.

Since their deformation characteristics mirror the maturing characteristics of the ceramic products being fired, cones provide an outstanding method of indicating heat work carried out during a firing.

It is usual to use a set of three consecutive cones: one to bend below the optimum firing point, one at the optimum firing point and one above. Orton Pyro-bars are supplied for use in kiln-sitters and mirror similar characteristics to that of cones.

Cone	Heating rate °C per hour		
	60°C	100°C	150°C
018	712	722	732
017	736	748	761
016	769	782	794
015	788	802	816
014	807	822	836
013	837	848	859
012	858	869	880
011	873	883	892
09	917	922	928`
08	942	948	964
07	973	979	985
06	995	1002	1011
05	1030	1038	1046
04	1060	1066	1070
03	1086	1093	1101
02	1101	1110	1120
01	1117	1127	1137
1	1136	1147	1154
2	1142	1152	1162
3	1152	1160	1168
4	1160	1171	1180
5	1184	1194	1205
6	1220	1230	1241
7	1237	1246	1255
8	1247	1259	1270
9	1260	1270	1280
10	1282	1293	1303
11	1293	1303	1312

# Conversion Tables

## WEIGHT

Kilograms		Pounds
0.454	1	2.205
0.907	2	4.409
1.361	3	6.614
1.814	4	8.819
2.268	5	11.023
2.722	6	13.228
3.175	7	15.432
3.629	8	17.637
4.082	9	19.842

To convert kilograms to pounds divide by 9 and multiply by 20. To convert pound into kilograms divide by 20 and multiply by 9.

## VOLUME

Litres		Gallons
4.546	1	0.220
9.092	2	0.440
13.638	3	0.660
18.184	4	0.880
22.730	5	1.100
27.276	6	1.320
31.822	7	1.540
39.368	8	1.760
40.914	9	1.980

To convert litres to pints multiply by 7 and divide by 4. To convert pints into litres multiply by 4 and divide by 7. To convert litres into gallons multiply by 2 and divide by 9. To convert gallons into litres multiply by 9 and divide by 3.

# Delivery Rates

## Postal Rates

Royal Mail Post	Up to 100g	Up to 250g	Up to 500g	Up to 750g	Up to 1kg
	£p	£p	£p	£p	£p
Packet (To Mainland UK postcodes only)	2.75	3.25	3.80	4.35	4.95

*Please Note: Channel Islands, Scottish Highlands, Eire, & Overseas - prices on application.*

## Parcel Carrier Rates

Fedex Delivery	EPS	EPM	EPL	Up to 25kg		Up to 50kg		Up to 75kg		Up to 100kg		Up to 125kg	
	£p	£p	£p	One Box		2 Boxes		3 Boxes		4 Boxes		5 Boxes	
				Next Day	3 day	Next Day	3 day	Next Day	3 day	Next Day	3 day	Next Day	3 day
All Mainland UK Postcodes (except Scottish Highlands)	5.23	6.28	7.33	10.30	9.28	18.00	16.72	25.50	23.56	33.00	30.40	40.50	37.24

*Please Note: Next Day and 3 Day refer to working days only (Saturday and Sunday not included). All deliveries provided are not timed - if you would like a timed delivery or weekend delivery, please contact us. All Parcel Carrier prices are subject to volume restrictions. We always endeavour to give you the best rate for delivery. Easi-Paks (Small, Medium & Large) are used when the total volume of an order is smaller than a 25kg box size. An additional; surcharge of £6.75 applies to all of the above prices for delivery to the Isle of Wight. Channel Islands, Scottish Highlands, Eire, & Overseas - prices on application.*

## Pallet Haulier Rates

Pallet Haulier Delivery	Up to 250kg		Up to 500kg		Up to 1000kg	
	Quarter Pallet		Half Pallet		Pallet	
	Priority Next Day	Economy 2/3 Day	Priority Next Day	Economy 2/3 Day	Priority Next Day	Economy 2/3 Day
PO, SO, GU6-8, 26-35	19.25	19.25	23.65	19.25	30.25	24.75
BN (except 20-24, 26-27)	27.94	25.74	31.24	27.94	33.44	31.24
GU (except 6-8, 26-35), KT	28.51	24.03	30.75	25.15	32.98	26.27
AB, IV, KW	96.25	85.25	101.75	85.25	112.75	96.25
AL, B, BB, BD, BL, CB, CH, CV, CW, DE, DN, LN, MK RH, SK, SL, SN, ST, TW	44.06	42.41	46.81	44.06	51.21	45.71
BA, BH, BS, CF, CM, CO, DH, DL, DT, HG, HU, IP, LL, ME, NP, NR, SP, SR, SS, TA, TN, TS	47.36	43.51	50.66	45.16	54.51	46.81
BN 20-24, 26-27	41.25	41.25	46.75	43.45	52.25	46.75
BR, CR, DA, EN, HA, IG, RM, SM, UB	45.37	42.96	49.01	44.61	52.86	46.26
CA	52.86	48.46	58.91	50.66	64.96	53.41
CT	50.66	46.81	53.96	48.46	57.81	50.11
DD, PH	80.63	77.06	80.63	77.06	95.21	78.71
DY, HD, HP, HR, HX, L, LD, LE, LS, LU, M, NG, NN, OL, OX, PE, PR, RG, S, SG, TF, WA	33.75	33.75	41.25	37.95	46.75	44.55
E, EC, EX, N, NW, PL, SA, SE, SW, SY, TR, W, WC	46.75	46.75	52.25	46.75	57.75	54.45
FY	47.36	43.51	50.66	45.16	56.50	47.36
LA, NE	50.11	46.81	58.91	44.18	64.96	51.21
TQ	43.06	41.94	53.14	44.18	62.10	50.90

*Please Note: All Pallet Haulier prices are subject to volume restrictions. Therefore, the above prices are not necessarily correct for equipment. For accurate costs - prices available on application.*

*Isle of Wight, Channel Islands, Scottish Highlands, R.O.I, & Overseas - prices available on application.*

# Delivery Notes

We have tried to minimize the cost of delivery by using nationwide carrier and pallet delivery services. Carrier delivery is normally made by 1500kg or 1750kg vehicles (this cannot be guaranteed). Pallet delivery will be via 10 ton lorries (again this cannot be guaranteed).

**IF ACCESS IS RESTRICTED OR CANNOT BE MADE BY LORRY WE MUST BE ADVISED IMMEDIATELY AS A SPECIAL VEHICLE MAY BE REQUIRED.**

This option may not be available in all areas! Delivery prices are for delivery to the nearest practicable point to the customer's premises and off-load. The drivers or their companies are not insured to carry goods into customer's premises or store. It is the customers responsibility from the point of off-loading.

Delivery prices for kilns and equipment are quotable on receipt of site information. Please call for details.

Some products, such as casting slips and kiln batts may need additional or special packaging. We will always advise at point of ordering if this applies.

## ECONOMY CARRIER NATIONWIDE

---

This is a delivery service based on your order reaching you within 3 working days from date of despatch. Normally goods need a signature to be left. If you are not at home at the time of delivery our carrier will leave a card and you will need to call your local depot to re-arrange the delivery. If you know you will not be in on the day of delivery we can instruct our carrier to leave your goods in a safe place. You must be aware though by taking this option you are accepting total liability for your order.

## PRIORITY CARRIER NATIONWIDE

---

This service applies to all Fastway deliveries to PO and SO Postcodes only. The EPS, EPM, and EPL services provided by Fedex nationally are also Next-Day as standard. These orders are despatched for delivery on the next working day. The same system for signature etc applies.

## DELIVERY TIMINGS

---

Royal Mail	1st class post - no specified time
Economy Nationwide	Within 3 working days (Monday to Friday 8.30a.m. to 6p.m.)
Priority Nationwide	Next working day (Monday to Friday 8.30a.m. to 6p.m.)
Economy Pallet	Within 3 working days (Monday to Friday 8.30a.m. to 6p.m.)
Priority Pallet	Next working day (Monday to Friday 8.30a.m. to 6p.m.)
Wheels, Kilns & Equipment	Subject to quotation

## RETURNS, REFUNDS & EXCHANGES

---

Returns for goods with a shelf life, such as plaster, are accepted only if the goods are damaged or faulty and must be returned within 7 days from receipt. All other goods need to be returned within 30 days of receipt and in original, complete and undamaged packaging. If the item has not been returned to us in fully resaleable condition, we reserve the right to refuse a refund. Please note any postage incurred by returning the item(s) to us will not be refunded nor will the original cost of delivery, unless in the case of damaged, faulty or goods mistakenly shipped.

## DAMAGED GOODS

---

All orders must be checked immediately and delivery notes/dockets must be marked accordingly if any damage is detected. When any parcels are opened after the carrier has left your premises and any items are found to be damaged we must be notified within 48 hours of delivery of your order. After this time we are unable to make a claim against our carriers.

# How to Order

## BY PHONE

---

Call 01243 265845 between 9.30am and 4.30pm Monday to Friday, When you call please, if possible have the following information at hand:

Customer account number (existing customers), item stock code and description and payment details (credit card/ debit card number, security code, expiry date and valid from date and issue number where applicable). We will confirm availability of all items ordered or call back with this information and total order value.

## BY FAX

---

Fax 01243 267582, again with your details, product details and payment method. Include your fax number and we will fax back a sales acknowledgement detailing order value and availability.

## BY EMAIL

---

Email [sales@claymansupplies.co.uk](mailto:sales@claymansupplies.co.uk) with your details, product details and payment method. We will email you a sales acknowledgement detailing order value and availability.

## DELIVERIES

---

All orders, with the exception of items such as wheels or kilns that are made to order, can be despatched on a 24 hour or 72 hour delivery system. It is our intention that all orders received by noon will be sent out that day. All orders received after that time should be despatched the next working day. When placing your order you will be advised when your order will be despatched and the estimated day of arrival.

## PAYMENT

---

Payment can be made by cash, credit/debit card or cheque. If cash is sent by post, this is at the customers own risk and we strongly recommend that you only use registered post. Cheques should be made payable to 'CLAYMAN SUPPLIES LIMITED'. Orders that are to be paid by cash or cheque are sent on receipt of the remittance. Orders supported by credit or debit cards are despatched immediately.

## PRICES

---

Please be aware that prices may change during the life of this price list. This is offered as a guide and we must emphasize that prices may change without notice. If the price of any goods you wish to buy is important we are pleased to supply you with a written quotation. Quotations secure the prices of goods for 30 days from the date they are issued.

# Where to Find Us!

Monday	9.30-1.00	2.00-4.30
Tuesday	9.30-1.00	2.00-4.30
Wednesday	9.30-1.00	2.00-4.30
Thursday	9.30-1.00	2.00-4.30
Friday	9.30-1.00	2.00-4.30
Saturday	9.30-12.00	CLOSED

## CONTACT DETAILS

### Postal Address:

Clayman Supplies Limited  
Morells Barn  
Park Lane  
Lower Bognor Road  
Lagness  
Chichester  
West Sussex  
PO20 1LR

### Telephone & Fax Numbers:

Telephone: 01243 265845 (24 hour ansaphone)  
Fax: 01243 267582

### Internet:

### Email:

General Information: [info@claymansupplies.co.uk](mailto:info@claymansupplies.co.uk)  
Sales: [sales@claymansupplies.co.uk](mailto:sales@claymansupplies.co.uk)  
Account queries: [accounts@claymansupplies.co.uk](mailto:accounts@claymansupplies.co.uk)  
Website: [www.claymansupplies.co.uk](http://www.claymansupplies.co.uk)

## VISITORS

At Clayman Supplies Limited you can be sure of a warm welcome on every visit. From 9.30 until 4.30, Monday to Friday, 9.30 until 12.00 on Saturdays (closed for lunch 1-2pm) we are open to provide you with a friendly service. If you need technical advice we suggest a telephone call before you visit will ensure that service is available. Also our easy parking will guarantee a relaxing time every time you call.

Groups are also welcome but prior notice would be appreciated to avoid disappointment. When you have made your selections we are happy to accept payment by cash, cheque, credit or debit card. VAT must be added to all prices at the current rate of 20%, except for books which are currently 0% rated.

Most of our goods are supplied by mail order, but should you decide to call we are sure you will enjoy your visit.

## IF YOU DECIDE TO TRAVEL

Lagness is situated on the picturesque coastal plain to the south of the Roman City of Chichester, a short car ride off the main coast trunk road (A27/M27). At the roundabout (Bognor Road Roundabout) where the A259 crosses the A27 take the Bognor exit. Follow the road, for about 4-5 miles, to a double mini-roundabout opposite the Royal Oak Public House, painted raspberry red or maroon. Turn right at the first of the mini roundabouts, you will be in a road called Chalcraft Lane. Drive the length of Chalcraft Lane until you come to another roundabout. Turn right, drive for half a mile. You will find a sign on your right for Park Farm. Turn into the lane. There are no signs indicating Clayman Supplies Limited. When you have turned you are in Park Lane, we are situated at the end.

## TYPICAL DRIVING TIMES TO LAGNESS

Bournemouth - 100 minutes  
Haywards Heath - 55 minutes  
Brighton - 45 minutes  
Midhurst - 30 minutes  
Chichester - 10 minutes  
Petworth - 35 minutes  
Crawley - 60 minutes  
Portsmouth - 25 minutes  
Dorking - 80 minutes  
Petersfield - 30 minutes  
Eastbourne - 85 minutes  
South London - 95 minutes  
Guildford - 60 minutes  
Southampton - 45 minutes  
Horsham - 40 minutes  
Tunbridge Wells - 100 minutes

## ORDERS & DELIVERIES

Goods are sent out on a daily basis via national carriers and a pallet delivery service. Carriage/ delivery is not included in the price of our goods. Our competitive rates for delivery are published in the Delivery Rates section at the back of this price list.

Our aim is to process all orders received immediately. All orders (with the exception of equipment that are available to order only) placed or received before midday will be despatched the same day via a next working day or three working day service. You can specify your preference. Any orders received or placed after midday are despatched by the next working day. If we are unable to fulfil this aim, because of lack of stock or excess of orders we will advise you and advise when your goods should be available for despatch.

We are also able to offer timed deliveries where urgency is an important factor, although this type of service does cost more. Be assured by our guarantee of quality, value for money and a support service that is second to none. See page 39 for details of how to order.

## CHOOSING

When it comes to purchasing equipment you are making an investment for the future and we pride ourselves in our expertise and advice in helping you make the right decision. If you are buying a wheel, we can advise on the qualities and design of each model. When considering a kiln often the best is not the cheapest, but included in our total package is our unique kiln helpline. Especially useful for the beginner, we are available at anytime to advise or solve that frustrating problem.

You can spend a long time regretting the wrong decision, but make the right decision with Clayman Supplies Limited!

## NO QUIBBLE EXCHANGE

If you find the products are not what you wanted or perhaps when you try a new clay you do not like it we will exchange any unopened products from the whole of our range without fuss. Simply bring back any product within 14 days (the time limit is because some products supplied have a shelf life!) and we will exchange these goods without any fuss. We do reserve the right to make a re-stocking charge if the packaging has been damaged. This service does not apply to wheels, kilns or videos, goods from these sections are normally supplied to order only.

## PRICES

All prices contained in this price list are ex-works from our main Chichester address, with the exception of some equipment which is dispatched direct from the manufacturer. All prices shown are exclusive of VAT at the current rate. Books are currently rated at 0% VAT.

## 7120 - STAFFORDSHIRE THROWING WHEEL

The Staffordshire Throwing Wheel is designed and constructed to give long trouble free service for the professional or amateur potter. This wheel is constructed using a polished wooden cabinet complete with a shelf and a two position adjustable upholstered seat, the wheel incorporates a large moulded plastic bowl. The drive mechanism is extremely smooth and offers low noise and vibration characteristics whilst giving excellent torque response so enabling large amounts of clay to be thrown. Fully reversible wheelhead. Optional extras include Easy-lift Wheelhead and batts.

**Technical Data:**

Motor: 0.5hp

Voltage: 220v/240v 50Hz single phase

Speed: 0-280 rpm

Wheelhead: 12"

Double sealed top bearing for extended life

Splash Tray: Moulded plastic

Size: 680mm wide, 820mm high, 1000mm long

Weight: 70kg (unpacked)



**Exquisite craftsmanship for £1530 + VAT**

# Notes

## 7210 - SLAB ROLLER

The Slab Roller has been designed to provide an extremely efficient and reliable method of producing slabs of clay for hand building or tiles.

It has been designed using vast experience in slab roller production and incorporates a rack and pinion drive system eliminating the need of maintenance from troublesome wire driven systems. The slab roller has fully collapsible legs so it can be easily transported and comes complete with a set of high quality rolling cloths.



Quality equipment for £845 + VAT

## 6160-40 - AURORA 40

The New Aurora is an entry level Top Loading Kiln, which are ideal for domestic situations and professional studios working on a small scale. This price includes the single programmable controller. Other controllers are available on request.

### Technical Details

Max Temp - 1260°C

Capacity - 1.41cu.ft.

Internal Dimensions: 400mm x 305mm (16" x 12"cm (inches)

External Dimensions: 559mm x 679mm x 560mm (22" x 23.75" x 22")

Weight: 46kg

kW: 3

Supply Required: 13amps



**Kiln + ST312 Controller for just £987.30 + VAT**

# Reference Notes

## PREPARING & STORING GLAZES

If you have bought a glaze in powder form or plan to mix your own glazes you will need to prepare them prior to use. You will need a sieve (80's for stoneware and 120's for earthenware), a large brush (lawn brush), two wooden slats, and two plastic containers. Before starting make sure all of your utensils are clean.

1. Partly fill one of the containers with water (a third of the container is reasonable but the exact amount will depend on the amount of glaze you are preparing. Trial and error is the best way of discovering the correct amount). Put the glaze powder into the water and mix. (N.B. Always wear a suitable mask when preparing glaze.)
2. Place the sieve over the second container using the slats as support. It is important to ensure it is stable. Pour the glaze mixture into the sieve until it is half full. Use the lawn brush to push the glaze slowly through the sieve, using a circular movement. Squeegee all of the material left in the first container into the sieve using a rubber kidney. Repeat the brushing process until all the glaze has passed through the sieve. Some material residue may be left in the sieve. If this is found dispose of it with care.
3. The product you now have is referred to as glaze slop and could be used immediately, although we recommend leaving the slop overnight before use.
4. When left the glaze slop will settle out. You will find a slurry of glaze material at the bottom of your container and clear water at the top. At this stage carefully pour off some of the clear water (try pouring off half as a starting point). Stir the glaze, ensuring all the slurry is dispersed in the water. A problem facing all beginners is what thickness the glaze should be. Glaze makers can make recommendations, but the final choice is with the potter and what results they want to achieve. A standard is that transparent glaze will always be thinner than opaque glazes and generally the analogy to single cream for consistency is used. The best way to find the desired thickness that suits you and also as a means of comparing different consistencies is to carry out trials. Make up test tiles with one hole near to one of the sides to enable it to be tied to the glaze tub for quick visual reference. If you use more than one clay make tiles in all the clays that may be used with the glaze. Glaze and mark the tiles. The results of firing these should provide you with very useful information. When you have tested and found your best consistency it is a good idea to weigh a known quantity of the glaze slop and record the result. This is often known or referred to as the pint weight. All future mixes of the glaze are then corrected to this pint weight by adding or removing water. Another way of measuring consistency is by using a hydrometer.
5. Always store mixed glazes in containers with tight fitting lids. This helps prevent contamination and water evaporating off the surface. As mentioned previously when using a glaze that has stood for a time always ensure all slurry is dispersed in the standing water. Occasionally it is good practice to re-sieve the glaze to ensure the glaze is always at its best.
6. It can be found that some glazes form a "pan", hard lump at the bottom of the container when stored. This is a particular characteristic of glazes containing high proportions of frit. This hard lump is often difficult to break up and disperse with the water, but it is essential this is done before the glaze is used. When the correct glaze consistency is achieved, a suspending agent can be added (proprietary suspending agent, bentonite or calcium chloride are all available for this use). Suspender should be added with caution. Refer to our special note on adding suspending agents.

# Reference Notes

## REFERENCE NOTES

The amount of water required to mix any glaze will vary from glaze to glaze depending on the clay content (Ball Clay, China Clay etc) of the glaze. The porosity of your bisque fired clay, the time taken in dipping into the glaze, and the maturing temperature of the glaze are all factors that need considering.

A glaze intended for spraying should always be of a thinner consistency than that used for dipping. Trying to spray a glaze with a specific gravity that is correct for dipping will nearly always result in the spray gun blocking.

The firing cycle used, the type and size of kiln used, the clay body and the thickness of the applied glaze are all factors that can or will affect the final result. It is always advisable to test variations prior to production runs of any ware.

We tend to talk in temperature when referring to ceramics, but the results that emerge from the kiln are the result of heat work. Heat work is a reference to the effect of heat over a period of time. This effect is best measured by the use of pyrometric cones, although most potters will acquire a kiln with a temperature controller. As a general rule if a firing runs for about eight hours, a controller set to 1000°C will equate to cone 06. At earthenware temperatures setting your controller to 1100°C will cause cone 03 to bend well and cone 02 will have started to go. At stoneware the difference is at its greatest. Cone 8 is considered to be the 1260° cone, but the kiln controller should be set to 1235-1240°C to produce comparable heat work. The best practice is to use cones in the firing so that the temperature set on the kiln controller can be compared to the cones at the end of the firing.

## THE USE OF GLAZE SUSPENDING AGENTS

Adding a glaze suspender to the glaze mix will not stop the materials dropping out of suspension on standing, but does prevent that slurry forming such a hard pan. The question is how much should be added. The answer is not simple as all glazes depending on their make up are different. Glazes made from lead frits may need approximately 10ml per 5 litres whereas glazes made with Alkaline Frit (normally raku glazes) suffer the problem more severely and will need much more. One can put too much suspender into a mix, therefore resolving the problem is very much a "suck it and see" method.

Firstly all glaze sediments, irrespective of the glaze, must be dispersed with the water. Once this has been achieved add glaze suspender sparingly. We suggest 10ml to 4-5 litres of glaze slop. If a hard sediment is formed again on standing add 5ml more suspender after dispersing all sediment again. Follow this procedure until the sediment that occurs on standing is soft and easily dispersed. Once you have achieved the correct balance of suspender to liquid glaze record the quantities for future reference.

Some suggested starting proportions of suspending agents are up to 2% bentonite mixed into dry glaze materials before adding water, or 0.1% Calcium Chloride dissolved in hot water and carefully added to the slop glaze. Too much Calcium Chloride will cause the liquid glaze to over flocculate and turn to jelly, so caution must be exercised when adding it. The effect will gradually wear off over time. Some glazes do not respond well to being stored in slop form - raku glazes, particularly those made using Alkaline Frit and those containing large quantities of colemanite or calcium borate. These should always be freshly prepared.

# Shimpo Whisper T

A new economy version of the Shimpo Whisper range. Offering a range of fantastic features at the price of other budget wheels. Made to Shimpo's normal high standard, the Whisper T offers the beginner the opportunity to acquire a wheel that has the specification demanded by professionals.

#### Technical Data:

Motor: 300w, AC230v, 50Hz  
Drive System: Direct drive DC Brushless Motor with electric speed control  
Speed Range : 0-250 rpm  
Speed Control: Remote foot pedal  
Wheelhead Direction: Clockwise/Counter clockwise  
Wheelhead: Light alloy casting, 300mm diameter  
Dimensions: 750mm x 572mm x 580mm  
Weight: 53kg

**Just £599.00 + VAT**



## Conditions of Sale

### 1. PAYMENT

Credit is allowed to Education Authorities and similar bodies and will be allowed to other customers on receipt of acceptable trade and bank references. Payment of accounts is to be made within 30 days nett of invoice date. **NON-PAYMENT WITHIN THE THIRTY DAYS WILL BE SUBJECT TO AN INTEREST CHARGE.** Unless otherwise agreed, where no credit account exists, all orders must be accompanied by remittance to the value of the order including carriage and VAT. Payment may be made by cash, cheque, credit or debit card.

### 2. PRICES

All goods are invoiced at prices ruling at date of despatch and are accepted only on this basis. All prices are subject to change without notice. All prices printed in price lists, advertising matter and elsewhere, submitted in writing or stated verbally are, unless otherwise stated, nett ex-works, carriage and VAT extra.

### 3. QUOTATIONS

Quotations for the delivery of goods, equipment and kilns will be submitted on receipt of all relevant information.

### 4. CARRIAGE

Off-loading and moving into position is the responsibility of the customer unless special arrangements have been made.

### 5. DELIVERED GOODS

Although we make every effort to adhere to stated delivery times, such times do not bind us and we shall be under no liability for any loss or damage of whatever nature caused by delay.

### 6. NON-DELIVERY/ PARTIAL LOSS

In the event customers must give notice in writing to the carrier and ourselves **within 24 hours** of receipt of goods.

### 7. DAMAGE

If possible, goods should be examined in the presence of the deliveryman and if any package appears damaged, the consignment/ delivery note should be endorsed accordingly. Customers must advise the carrier in writing of any damage **within 24 hours** of delivery and present a detailed claim to the carrier within seven days of delivery, with copies to ourselves.

### 8. DESCRIPTION & SPECIFICATION

All descriptions, specification, drawing or illustrations shown in literature are advertising matter, given verbally or in writing are given for general guidance only and no warranty or guarantee of any kind is to be implied nor is such information to form part of any contract. In accordance with our policy of constantly improving products we reserve the right to change specification or delete any items from our catalogue, without prior notice. **THE BUYER IS STRONGLY RECOMMENDED TO TEST ALL GOODS BEFORE USING THEM AND WHERE A BULK MATERIAL IS TO BE USED IT IS RECOMMENDED THAT A SAMPLE BE TESTED FIRST.**

### 9. LIABILITY

We accept no liability for death, injury or damage of any kind whether to person or property arising out of or in connection with any material, goods or services by us.

### 10. OWNERSHIP

The ownership of goods bought shall not pass to the Purchaser until the Purchaser has paid to the Company the total purchase price, including VAT, in respect of said goods.



**CLAYMAN**  
Supplies Limited

Morells Barn • Park Lane • Off Lower Bognor Road • Lagness • Chichester • West Sussex • PO20 1LR  
Telephone: +44 (0) 1243 265845 (2 lines + answerphone) • Fax: +44 (0) 1243 267582

Email: [info@claymansupplies.co.uk](mailto:info@claymansupplies.co.uk) • [www.claymansupplies.co.uk](http://www.claymansupplies.co.uk)

## PRICING POLICY

---

We have found recently that the price of products featured in our range can fluctuate. It has always been our policy to maintain our prices for as long as possible during the lifetime of a price list. Unfortunately we now find it necessary to instigate a policy that means prices can change more often than previously.

Please be aware we now operate a price ruling at time of despatch. We will do our best to maintain active prices in our price list and on our website, but it must be accepted that these may vary.

Should you need fixed prices please request a quotation. We will be pleased to provide you with a you quote at any time and these prices are then fixed for 30 days from the date of the quote.

We are sorry for any inconvenience this change in policy may cause, but can assure you that we will always endeavour to offer the keenest prices in this market.

June 2011